

SHORING PLAN
WATER MAIN REPLACEMENT PROJECT
PROJECT NO. 50098

REV #0

DESIGN CALCULATIONS
March 12, 2025

PREPARED BY:
SCOTT F CANNON, PE



MZB ENGINEERING, INC

[TEL: 949.254.4792](tel:949.254.4792)

engineering@mzbinc.com

www.mzbinc.com



M E M O

To: Date: March 12, 2025
From: Scott Cannon, P.E.
Project: Water Main Replacement Project CIP Project no. 50098
RE: Shoring Plan Rev. 0

Per your request, Shoring Plan Rev 0, provided by _____ has been reviewed and take no exception to the shoring plan for a Type C soil using Trench Shoring vertical aluminum hydraulic shoring. Any deviation from this workplan that is not permitted for Type C soil or any other equipment not listed on the Surcharge Setback Table shall be reported to MZB Engineering, Inc, prior to proceeding with work. The competent person shall continually monitor the shored excavation for changed conditions per the manufacture's recommendation.

Please feel free to contact MZB Engineering if you have any questions regarding the above information.

SHORING PLAN

Project Name: Water Main Replacement Project CIP Project No.50098



TABULATED DATA

**VERTICAL
ALUMINUM
HYDRAULIC
SHORING**

2021



CER, Inc.
Construction Engineering Resource,
Inc.
1837 Wright St.
Santa Rosa, CA 95404

Effective Date: April 15, 2012

Corporate Office
Trench Shoring Company
206 N. Central Ave.
Compton, CA 90220

310-327-5554
TrenchShoring.com



"Commitment To Safety & Service"
Since 1973

Contents

Contents 1
About Trench Shoring Safety Vertical Aluminum Hydraulic Shore Tabulated Data 1
Vertical Aluminum Hydraulic Shoring Quick Use Guide 3
Hydraulic Shore Safety Issues 7
Vertical Aluminum Hydraulic Shores Description 9
General Information for Use of Vertical Aluminum Hydraulic Shores 9
Classification of Soil Types 12
Vertical Aluminum Hydraulic Shore Selection Guide 12
Vertical Aluminum Rail Specification 15
Typical Vertical Aluminum Hydraulic Rail Dimensions 16
Hydraulic Cylinder Specifications 17
Vertical Aluminum Hydraulic Shore Installation and Removal Procedure 19
Installation steps for use of Vertical Aluminum Hydraulic Trench Shores 21
Safe Handling and Use of Trench Shores 27
Subpart P Additional Requirements Related to Hydraulic Shoring with Commentary 30

**About Trench Shoring Safety Vertical Aluminum Hydraulic Shore
Tabulated Data**

Vertical Aluminum Hydraulic Shores were first developed in the late 1950’s and early 1960’s. To this day, the shores are built practically the same as they were then. There are several major manufacturers all with similar parts and their own version of manufacturer’s tabulated data. Some parts are also interchangeable. Due to the interchangeability and variety of tabulated data available, Trench Shoring has developed this set of universal tabulated data under;

Federal OSHA 29CFR, Part 1926, Subpart P-Excavations and Trenches

1926.652(c)(3)-**Option (3)** - Designs Using other Tabulated Data.

1926.652(c)(3)(i) -Design of support systems, shield systems, or other protective systems shall be in accordance with tabulated data, such as tables and charts.

Note that **manufacturer’s** tabulated data is developed under;

1926.652(c)(3)-**Option (2)** - Designs Using Manufacturers Tabulated Data.

Federal OSHA 29CFR also has tabulated data for vertical hydraulic shores under;

1926 Subpart P-**Appendix D**-Aluminum Hydraulic Shoring for Trenches



VERTICAL ALUMINUM HYDRAULIC SHORING TABULATED DATA

2

Federal OSHA 29CFR only allows use of Appendix D when Option 2 is not available. Appendix D tabulated data is more restrictive than manufacturer's tabulated data in two major ways;

1. There is no category for OSHA Type C soil
2. The tables only allow trench depths to 20 ft deep

Use of this Trench Shoring Universal Vertical Aluminum Hydraulic Shore tabulated data will result in selection of a system that, at a minimum, conforms to manufacturers tabulated data developed by;

- Allied Tren-Shore
- Cerda
- Efficiency Corporation
- GME Corporation
- Kundle Tren-Shore
- Pacific Shoring, LLC
- Quick Shore
- Safety Shore
- Speed Shore Corporation

In some cases, this tabulated data will be more restrictive than the manufacturers version; however it is always less restrictive than the OSHA Appendix D version. The competent person utilizing this tabulated data should have a clear understanding that he is selecting a shoring system under Option 3, Designs Using other Tabulated Data.

Vertical Aluminum Hydraulic Shoring Quick Use Guide

This quick use guide provides a step-by-step methodology for determining the proper configuration of a vertical aluminum hydraulic shoring system. Proper use of this process will result in a system constructed in accordance with the tabulated data presented here. To be in conformance with this tabulated data, all of the information presented in this document shall be read and understood by the person utilizing this data.

1) VERTICAL SPACING

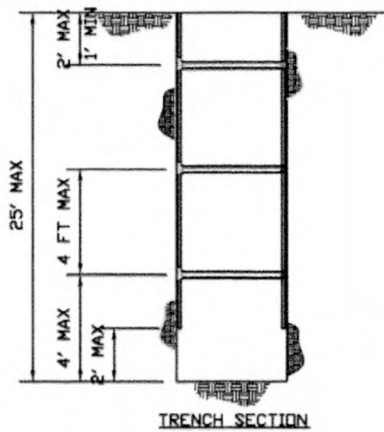

2) HORIZONTAL SPACING

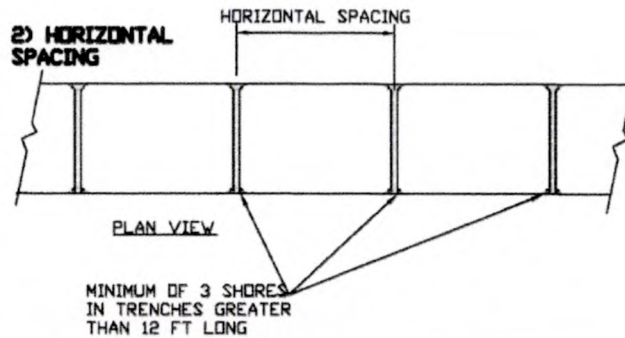
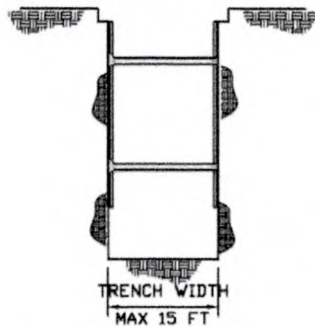

Table 5-HORIZONTAL SHORE SPACING			
Depth ft	OSHA Soil Type		
	A	B	C-60
over 5 to 10	8	8	6
over 10 to 15	8	6	4
over 15 to 20	8	6	4
over 20 to 25	6	4	3

3) TRENCH WIDTH



TRENCH WIDTH OVERSLEEVE REQUIREMENTS:

- 0 TO 8 FT WIDE NO OVERSLEEVE REQUIRED TYPE A & B SOIL
- 8 TO 12 FT WIDE 3" ROUND ALUMINUM OVERSLEEVE
- 12 TO 15 FT WIDE 3.5" X 3.5" X 1/4" WALL SQUARE STEEL OVERSLEEVE

4) SHEETING

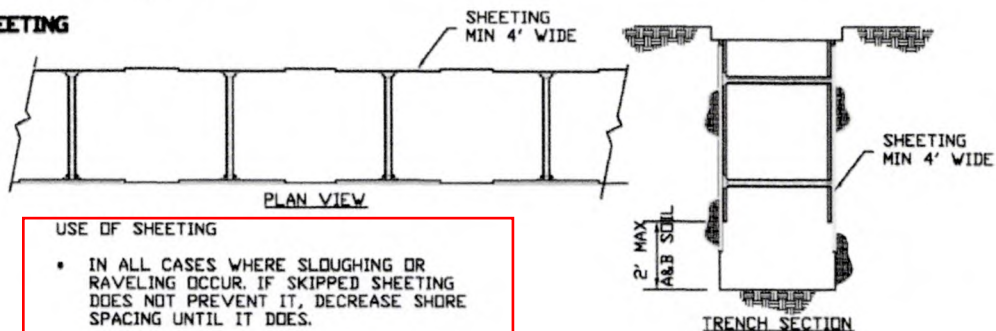

USE OF SHEETING

- IN ALL CASES WHERE SLOUGHING OR RAVELING OCCUR, IF SKIPPED SHEETING DOES NOT PREVENT IT, DECREASE SHORE SPACING UNTIL IT DOES.
- TYPE C-60 SOIL
- MAXIMUM 2 FT ABOVE BOTTOM IN TYPE A & B SOIL TO BOTTOM IN C-60 SOIL

5) STACKED SHORES

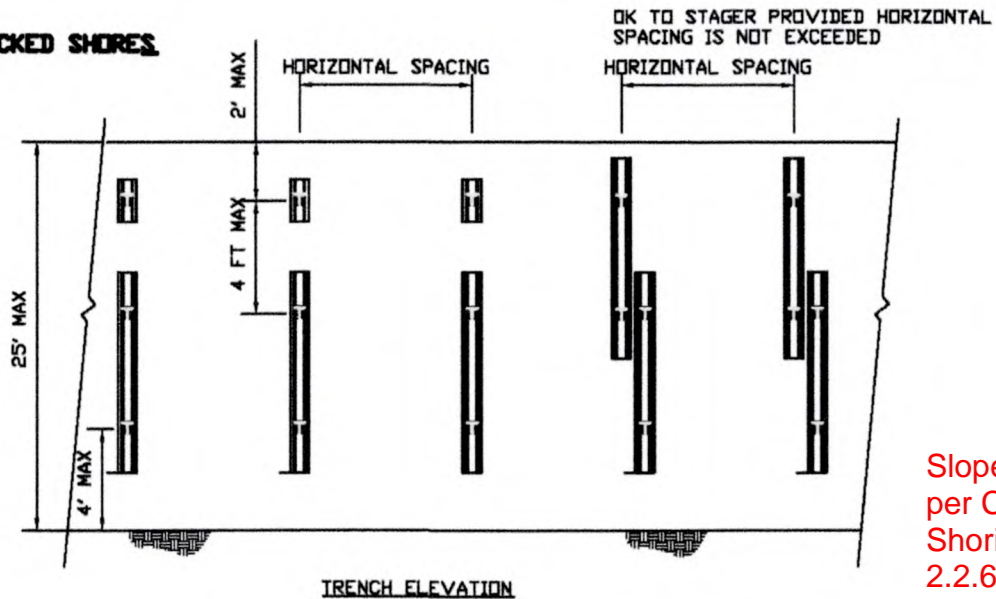

Slope for Type C Soil per Caltrans Trench and Shoring Manual Section 2.2.6 (3H:1V)

6) SINGLE SHORE IN 6 FT TRENCH

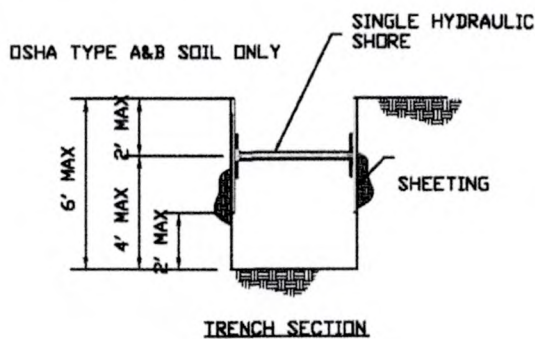

7) SLOPED TRENCH WITH HYDRAULIC SHORES

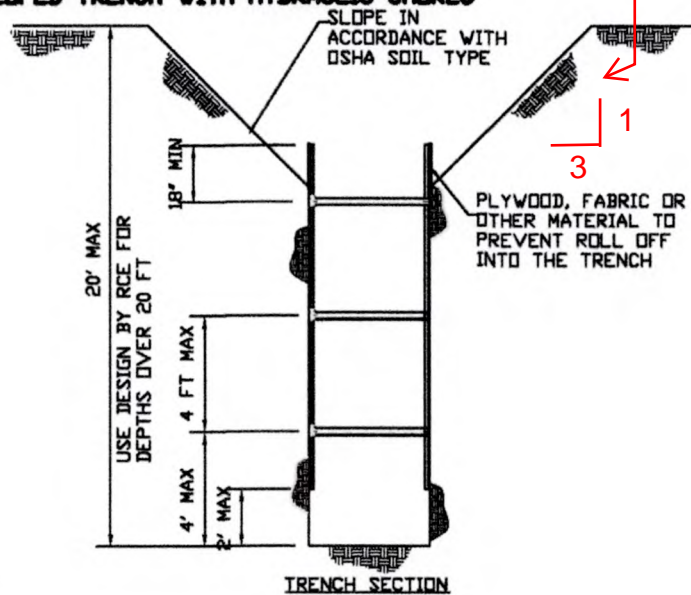

8) SOIL CONTACT WITH CYLINDERS

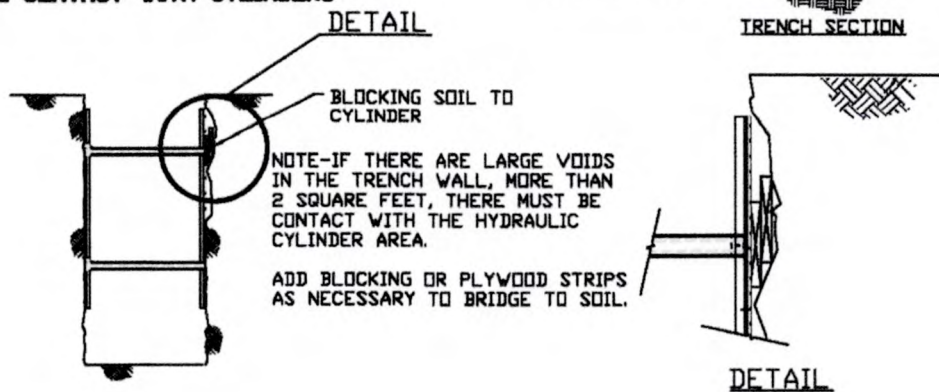

9) NON LINEAR TRENCH CONFIGURATIONS

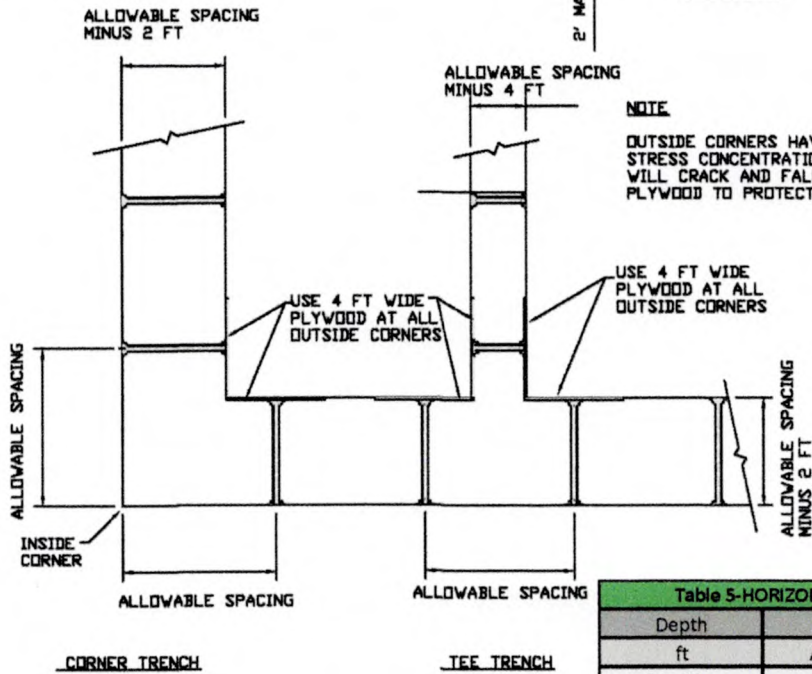
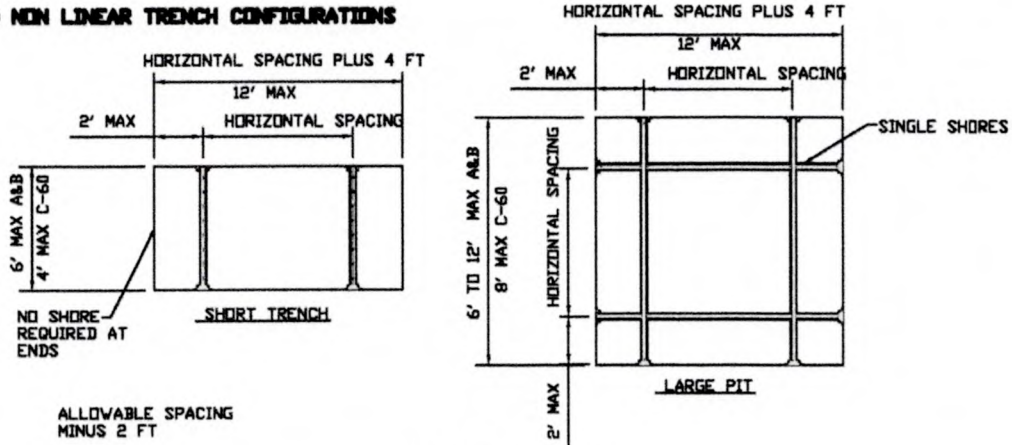
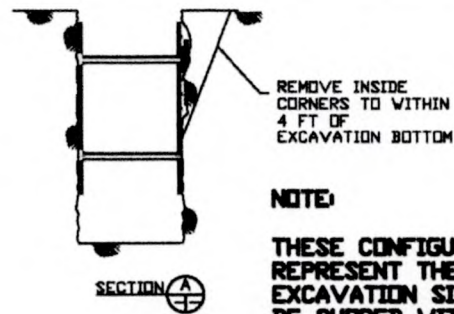
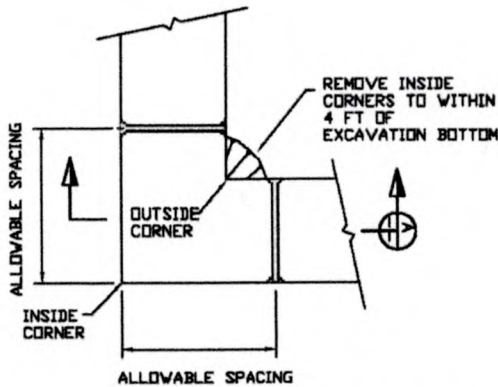

Table 5-HORIZONTAL SHORE SPACING			
Depth ft	OSHA Soil Type		
	A	B	C-60
over 5 to 10	8	8	6
over 10 to 15	8	6	4
over 15 to 20	8	6	4
over 20 to 25	6	4	3



NOTE:

THESE CONFIGURATIONS REPRESENT THE LIMITS OF EXCAVATION SIZES THAT CAN BE SHORED WITH 2" VERTICAL HYDRAULIC SHORES

CORNER AND T TRENCH ALTERNATIVE TO USING PLYWOOD AT OUTSIDE CORNERS

10) SURCHARGE LOADING

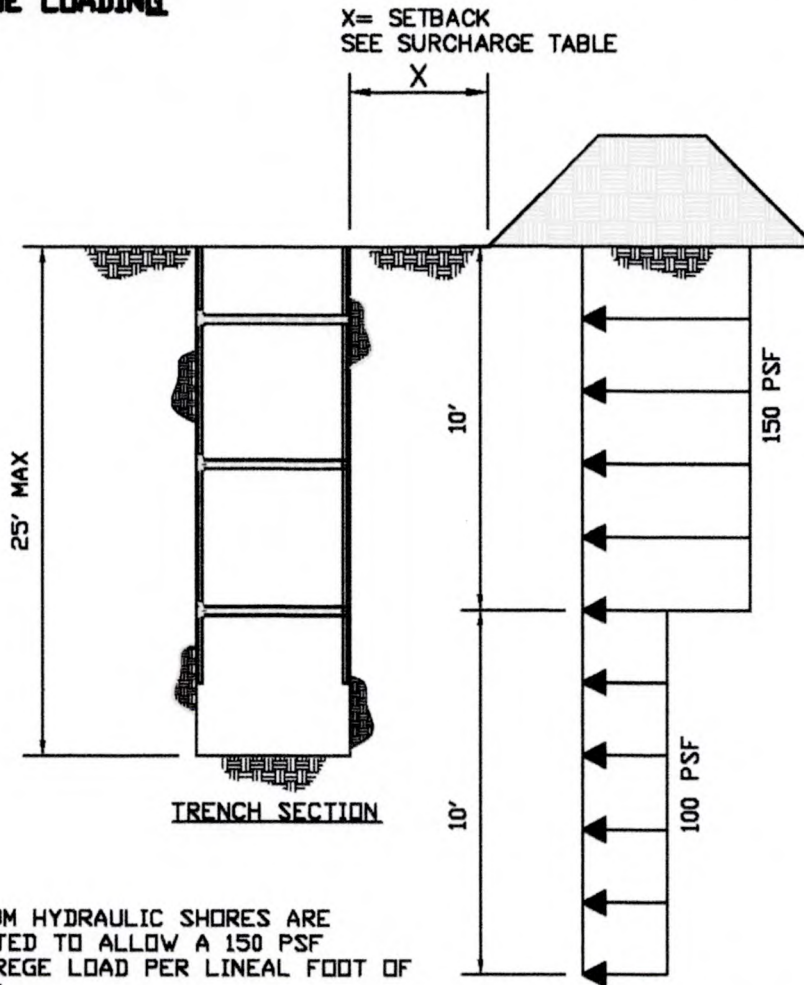

NOTE

ALUMINUM HYDRAULIC SHORES ARE
TABULATED TO ALLOW A 150 PSF
SURCHARGE LOAD PER LINEAL FOOT OF
SPACING

SURCHARGE LOADING DIAGRAM

SURCHARGE AFTER 20 FT DEEP IS 50 PSF OR LESS

SURCHARGE SETBACK TABLE			
Surcharge	Setback Distance x	Surcharge	Setback Distance x
K-Rail	1 ft	3 Cy Loader	2 ft
HS20-44 Traffic	4 ft	5 Cy Loader	3 ft
Spoil Pile 4 ft high	2 ft	225 Excavator	2 ft
Backhoe	2 ft	325 Excavator	3 ft
Equipment < 20,000 lb	2 ft	Dump Truck and Haul Trucks	3 ft
Equipment >20,000 lb	3 ft	12 CY Concrete Truck	3 ft
		Boom Truck Pad	6 ft

Table Notes:

- 1 These setbacks limit horizontal shoring loads to 72 psf for 0 to 10 ft and 50 psf 10 to 20 ft
- 2 Provide separate surcharge analysis for all cranes and structures within 15 ft of the excavation
- 3 Table setbacks are for open trenches. When traffic covers are in place HS20-44 traffic can pass over the covered excavation

Hydraulic Shore Safety Issues

1) SHORE FOLD UP

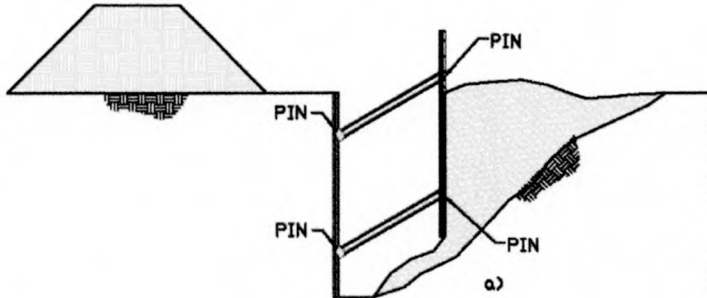

PROBLEM
SHORES WITH 2 HYDRAULIC CYLINDERS OR 2 SINGLE CYLINDER SHORES CAN ROTATE DUE TO UNBALANCED LOADING ON ONE SIDE

SOLUTION
SET EVERY THIRD SHORE SO THAT THE SHORE ROTATION IS OPPOSITE

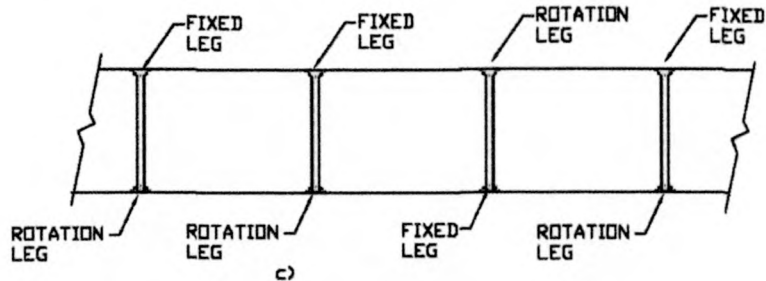
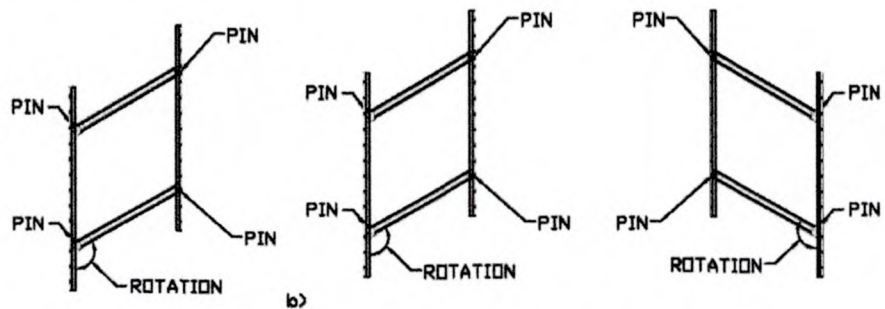

PLAN VIEW

2) FINGER PINCH

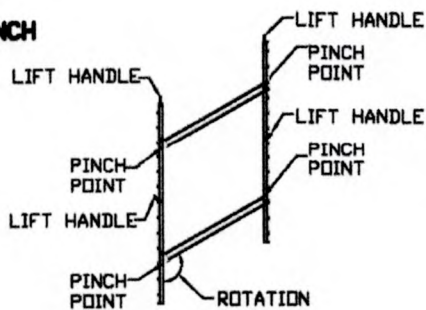

PROBLEM
FINGERS CAN BE PINCHED OR SEVERED BETWEEN THE RAIL AND THE CYLINDER BLOCK WHEN MOVING OR SETTING SHORES

SOLUTION
USE LIFT HANDLES ONLY TO LIFT AND SET THE SHORE

3) REMOVAL OF SOIL ARCH

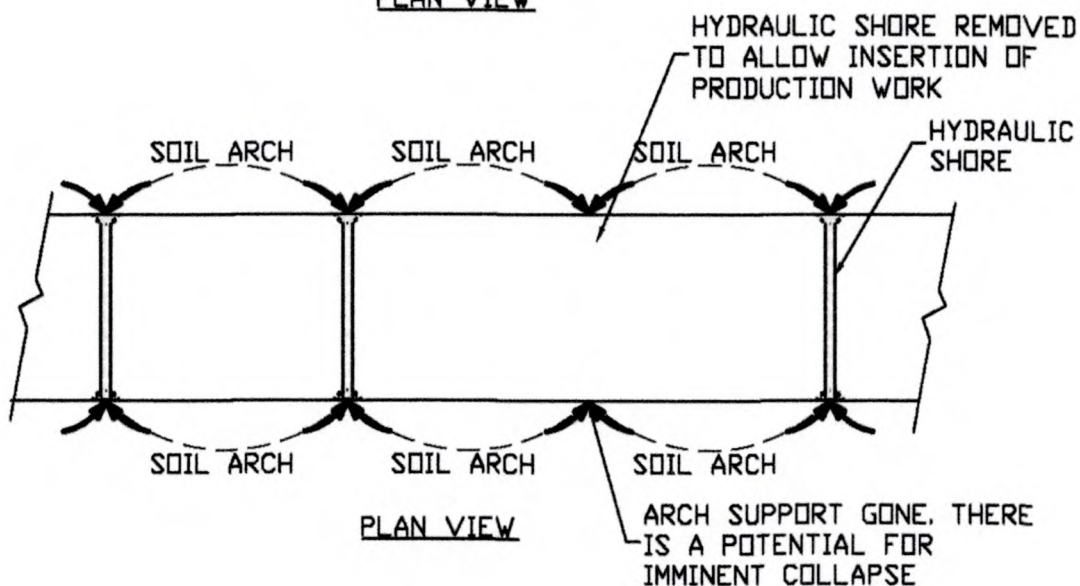
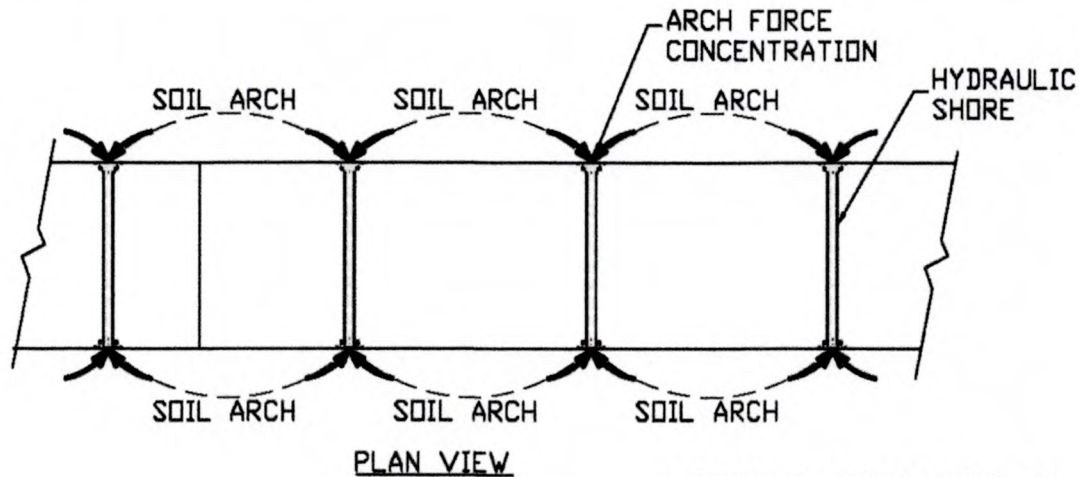

PROBLEM

SOIL ARCHING IS ESTABLISHED WHEN SHORES ARE INSTALLED. TEMPORARY OR PERMANENT REMOVAL OF THE SHORE IS A POTENTIAL FOR IMMINENT COLLAPSE

SOLUTION

1. WHEN REMOVING SHORES KEEP BACKFILL CLOSE TO SHORES BEING REMOVED
2. WHEN REMOVING AND RESETTING SHORES TO ALLOW PLACEMENT OF PRODUCTION WORK USE REMOTE EQUIPMENT SUCH AS BACKHOE OR BOOM TRUCK TO PICK AND RESET SHORES. OPERATE SHORE HYDRAULICS FROM SHORED AREA.



VERTICAL ALUMINUM HYDRAULIC SHORING TABULATED DATA

9

Vertical Aluminum Hydraulic Shores Description

Vertical Aluminum Hydraulic Shores are constructed from standard duty or heavy-duty vertical rails attached to 2" hydraulic cylinders. The rail lengths vary from 18" to 20 ft long. The cylinders can extend from 18" to 88". Cylinder extensions can be added to obtain lengths to 15'. The hydraulic cylinder consists of a 2" OD piston, a 2" ID x 3/16" barrel, and a 3" OD x 3/16" oversleeve. The cylinders provide a 23,000 lb safe working load for cylinder bulging at a 1.5 factor of safety. At lengths 8 ft to 12 ft an additional 3" round aluminum over sleeve is required and at 12 ft to 15 ft a 3.5" x 3.5" x 3/16" wall a square steel oversleeve is required to prevent buckling. Based on the principal of soil arching Vertical Aluminum Hydraulic Shores can be spaced horizontally as much as 8 ft apart without sheeting on the trench walls. Plywood sheeting is used either attached or separate behind the rails to prevent the trench walls from sloughing or raveling.

Vertical Aluminum Hydraulic Shores are installed from outside the excavation. The shores are hinged so that they can be folded when lowered into the trench and then opened up and pressurized with a hydraulic hand pump. The hydraulic fluid is water soluble, environmentally safe, and biodegradable. Rails 5 ft long and less can typically be moved, set, and removed by a two man crew. Larger shores are typically handled by backhoe, loader or boom truck.

Vertical Aluminum Hydraulic Shores are typically used in linear trench applications in OSHA Type A, Type B, and Type C-60 soils at depths to 23 ft and trench widths to 15 ft. Constraints such as the requirement that the bottom cylinder be set a maximum of 4 ft from the bottom of the excavation, bedding requirements, and pipe wall thicknesses limits the pipe diameter or duct height to approximately 36" maximum. The 8 ft maximum horizontal spacing limits large pipe lengths to approximately 8 ft, while smaller diameters with longer lengths to 20 ft such as PVC sewer and water lines can be maneuvered between the cylinders to fit into the trench.

General Information for Use of Vertical Aluminum Hydraulic Shores

1. The vertical aluminum hydraulic shoring system tabulated here is based on requirements of Federal OSHA 29CFR, Part 1926, Subpart P-Excavations and Trenches

1926.652(c)(3)-Option (3) - Designs Using other Tabulated Data.

1926.652(c)(3)(i) -Design of support systems, shield systems, or other protective systems shall be in accordance with tabulated data, such as tables and charts.

All provisions of Subpart P apply when utilizing this tabulated data. The contractor's competent person shall use this data to select:

- allowable trench depth
- vertical and horizontal shore spacing
- proper oversleeve requirement based on trench width
- plywood use requirements

2. The competent person utilizing this tabulated data shall be experienced and knowledgeable of all requirements of Subpart P, and trained in the use and safety procedures for aluminum vertical hydraulic shores.
3. For specific Subpart P requirements regarding aluminum hydraulic shoring that is in addition to the tabulated data requirements, see OSHA Subpart P additional requirements related to aluminum hydraulic shoring. Some of these requirements are listed at the end of this document, See **Header PG. 29**
4. Use of this tabulated data is dependent on first classifying the soil in accordance with OSHA Appendix A, Soil Classification. Classification shall be just prior to installing Vertical Hydraulic Shoring. Soil conditions may change at a later date and require Vertical Hydraulic Shoring to be reset at a different spacing.

5. Hydraulic vertical shores are tabulated based on the effect of a 20,000 lb surcharge load set back 2 ft from the edge of the trench and the equivalent weight effect of the OSHA soil type, See classification of soil types, 2.

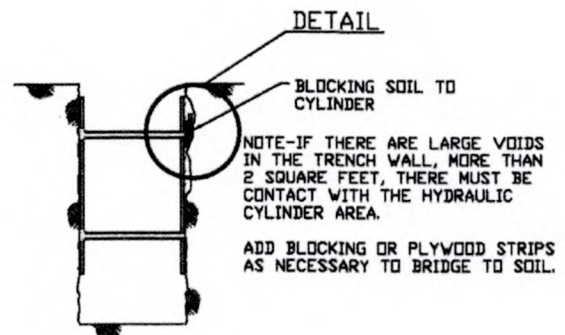
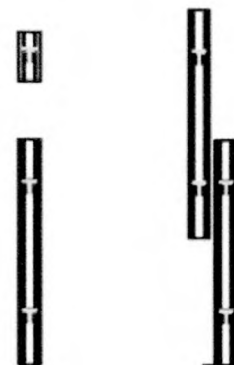

Figure 1. – See note 7

6. The depth and spacing given in **Table 1** governs the use of Vertical Hydraulic Shores and not tabulations given in OSHA Appendix C
7. Faces of excavations shall be vertical and there shall be in contact with the soil at each cylinder, **Figure 1**.
8. Shores shall be set near vertical; however, they may be set as much as 30 degrees from vertical provided that vertical and horizontal spacing is maintained.
9. Vertical Hydraulic Shores may be stacked or longitudinally lapped, **Figure 2**, provided shore spacing is maintained.



Stacked Lapped
Figure 2. – See note 9



VERTICAL ALUMINUM HYDRAULIC SHORING TABULATED DATA

10. Trenches maximum 12 ft long or horizontal spacing 4 ft or less shall have a minimum of 2 shores set in accordance with spacing requirements. Longer trenches shall have a minimum of 3 shores set at required spacing. See **Figure 3**.
11. Shores shall be installed and removed from outside the trench, see installation and removal procedure.
12. Single cylinder shores may be used in place of multiple cylinder shores provided that horizontal and vertical spacing is maintained.
13. The competent person shall continually monitor the shored excavation for changed conditions such as water seepage, soil movement cracks at the surface, sloughing or raveling, proper surcharge load weight less than 20,000 lbs and setback a minimum of 2 ft and damaged shores.
14. Workers shall always enter, exit, and work inside the shored area of the trench.

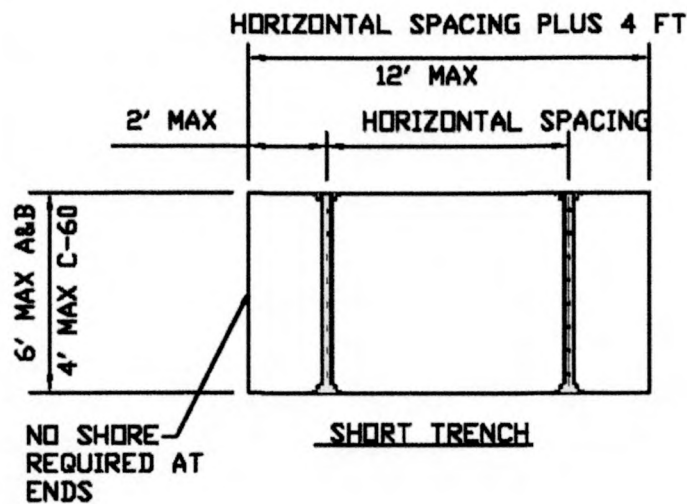

Figure 3. - Short trench, See Note 10



Classification of Soil Types

1. Soil classification shall be in accordance with OSHA Appendix A and classified just prior to installing hydraulic vertical shores. Soil conditions may change at a later date and require hydraulic vertical shores to be reset at a different spacing.

2. The equivalent weight of OSHA soil types* is assumed to be as follows:

• OSHA Type "A" Soil	25 PSF per ft of depth
• OSHA Type "B" Soil	45 PSF per ft of depth
• Type "C-60" Soil	60 PSF per ft of depth**
• OSHA Type "C" Soil	80 PSF per ft of depth

* These equivalent weights were adapted from OSHA 1926 Subpart P App C, Timber Shoring for Trenches, Tables C-1.1, C-1.2, and C-1.3

** Type C-60 soil is not identified or classified in OSHA Appendix A

3. Type C-60 soil is;

- soil that does not qualify as OSHA Type A, or Type B, can be cut with vertical walls and will stand up long enough to safely insert and pressurize the hydraulic shore,
- the water table must be at or below the bottom of the excavation with no visible water seeping from the sides of the excavation

4. Hydraulic shores shall not be used in OSHA Type C-80 Soil



**VERTICAL ALUMINUM
HYDRAULIC SHORING
TABULATED DATA**

Vertical Aluminum Hydraulic Shore Selection Guide

Table 1 Vertical Hydraulic Shore Selection Guide⁽¹⁾						
Depth of Trench (ft)	Hydraulic Cylinder Requirements					Sheeting
	Maximum Horizontal Spacing (ft)	Maximum Vertical Cylinder Spacing (ft)	Cylinder Size Width of Excavation (ft)			
			to 8	8 to 12	12 to 15	
TYPE "A" Soil						
to 10'	8'	4'	2"	2"	2"+OS2	NOTE 2
10' to 15'	↓	↓	↓	2"	2"+OS2	↓
15' to 20'				2"+OS1	2"+OS2	
20' to 25'	↓	↓	↓	2"+OS1	2"+OS2	↓
TYPE "B" Soil						
to 10'	8'	4'	2"	2"	2"+OS2	NOTE 2
10' to 15'	7'	↓		2"	2"+OS2	
15' to 20'	6'			2"+OS1	2"+OS2	
20' to 25'	5'	↓		2"+OS1	2"+OS2	NOTE 3, 4
TYPE "C-60" Soil						
to 10'	6'	4'	2"	2"	2"+OS2	NOTE 3
10' to 15'	5'	↓	↓	2"	2"+OS2	↓
15' to 20'	4'			2"+OS1	2"+OS2	
20' to 25'	3'	↓	↓	2"+OS1	2"+OS2	NOTE 3, 4
OS1 = 3"X3/16" Wall Aluminum Oversleeve						
OS2 = 3.5"x3.5"x3/16" Wall Steel Oversleeve						

Notes

- Soil shall first be classified in accordance with OSHA Appendix A Soil Classification for use with this selection guide. Type C-60 soil is OSHA Appendix A Type C soil that will stand up long enough to install the hydraulic shores.
- Sheeting is required at any depth whenever sloughing or raveling occur. If sloughing or raveling occurs between sheeting, decrease spacing until it is prevented. See **Table 2** for allowable sheeting. Sheeting may be attached to jack or set into trench separately.

Table 2-ALLOWABLE SHEETING			
Plywood		Other Materials	
3/4" Finn Form		1/2" thick steel plate 4 ft wide x depth	
3/4" Omni Form		Steel sheet piling	
3/4" plyform, Class 1 Exterior		Aluminum sheet piling	
3/4" HDO, High Density Overlay		Buildable box panels	
3/4" HDO, High Density Overlay			
3/4" 14 Ply Artic White Birch			
1-1/8" CDX			
2 sheets of 3/4" CDX			
Timber Lagging Set Horizontal			
Thickness	Soil Type/Span		
	A	B	C-60
2"	4 ft		
3"	5 ft	4 ft	
4"	8 ft	6 ft	4 ft
DF#2 or Oak			



**VERTICAL ALUMINUM
HYDRAULIC SHORING
TABULATED DATA**

3. Sheeting is required at this depth.
4. Sheeting must extend to the bottom of the excavation.
5. This tabulation includes lateral loading from equipment weighing 20,000 lbs or less and a maximum 2 ft high spoil pile set back a minimum of 2 ft. The competent person shall determine the effect of all other surcharge loads and reduce hydraulic shore spacing as required to resist those loads.

Vertical Aluminum Rail Specification

VERTICAL RAIL SPECIFICATION SHEET

SECTION PROPERTIES	STANDARD RAIL	HEAVY DUTY RAIL
MATERIAL	ALUMINUM	ALUMINUM
ALLOY	6061-T6	6061-T6
AREA	2.45 in ²	3.47 in ²
WEIGHT	2.94 plf	4.17 plf
SECTION-MODULUS - TOP (LEG SIDE)	0.44 in ³	1.25 in ³
SECTION-MODULUS - BOTTOM (BLADE SIDE)	1.29 in ³	2.38 in ³
EQUIVALENT TIMBER SIZE * (#2 DOULAS FIR)	3x10 (FLAT)	4x10 (FLAT)

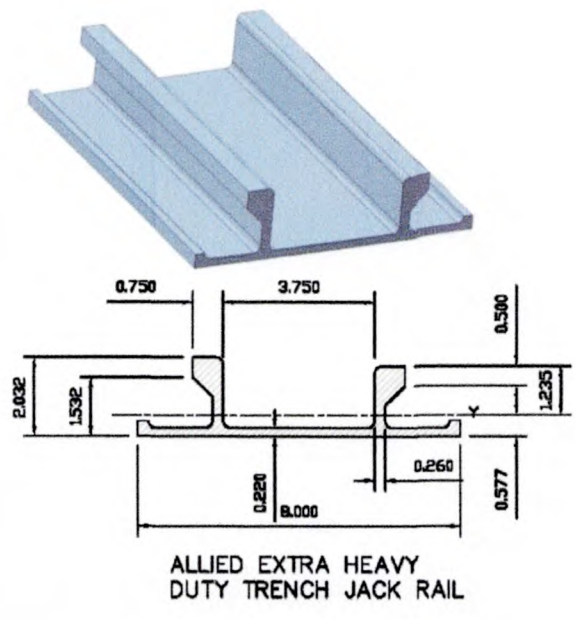
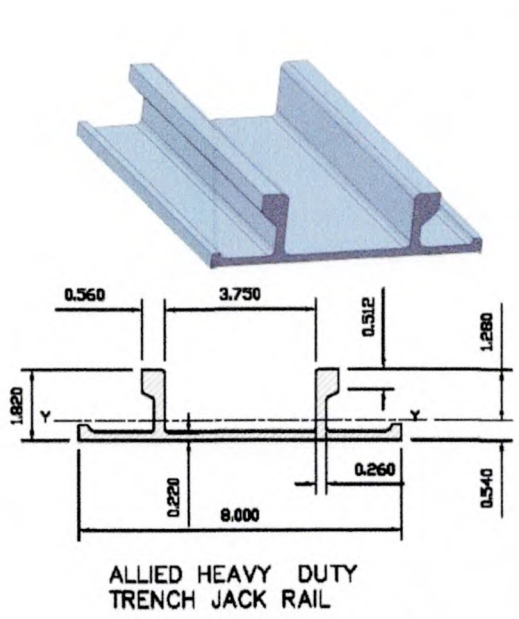
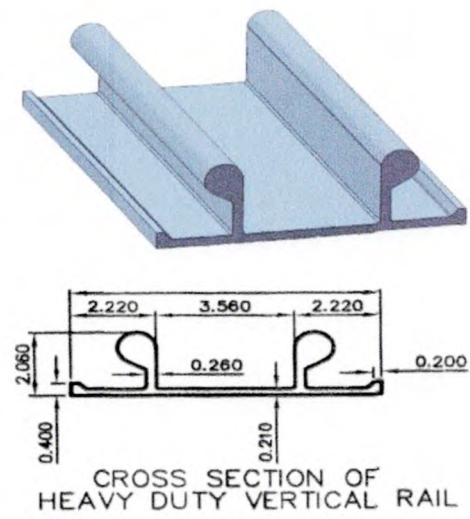
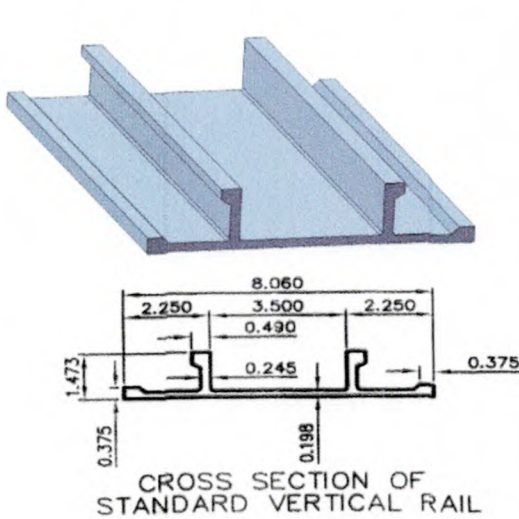

AREA	=3.08 IN ²
WEIGHT	=3.52 PLF
MOMENT OF INERTIA	=0.52 IN ⁴
SECTION MODULUS TENSION	=0.99 IN ³
SECTION MODULUS, COMPRESSION	=2.37 IN ³

AREA	=3.49 IN ²
WEIGHT	=3.98 PLF
MOMENT OF INERTIA	=1.565 IN ⁴
SECTION MODULUS TENSION	=1.26 IN ³
SECTION MODULUS, COMPRESSION	=2.71 IN ³

Figure 4. Vertical Rail Specifications

Typical Vertical Aluminum Hydraulic Rail Dimensions

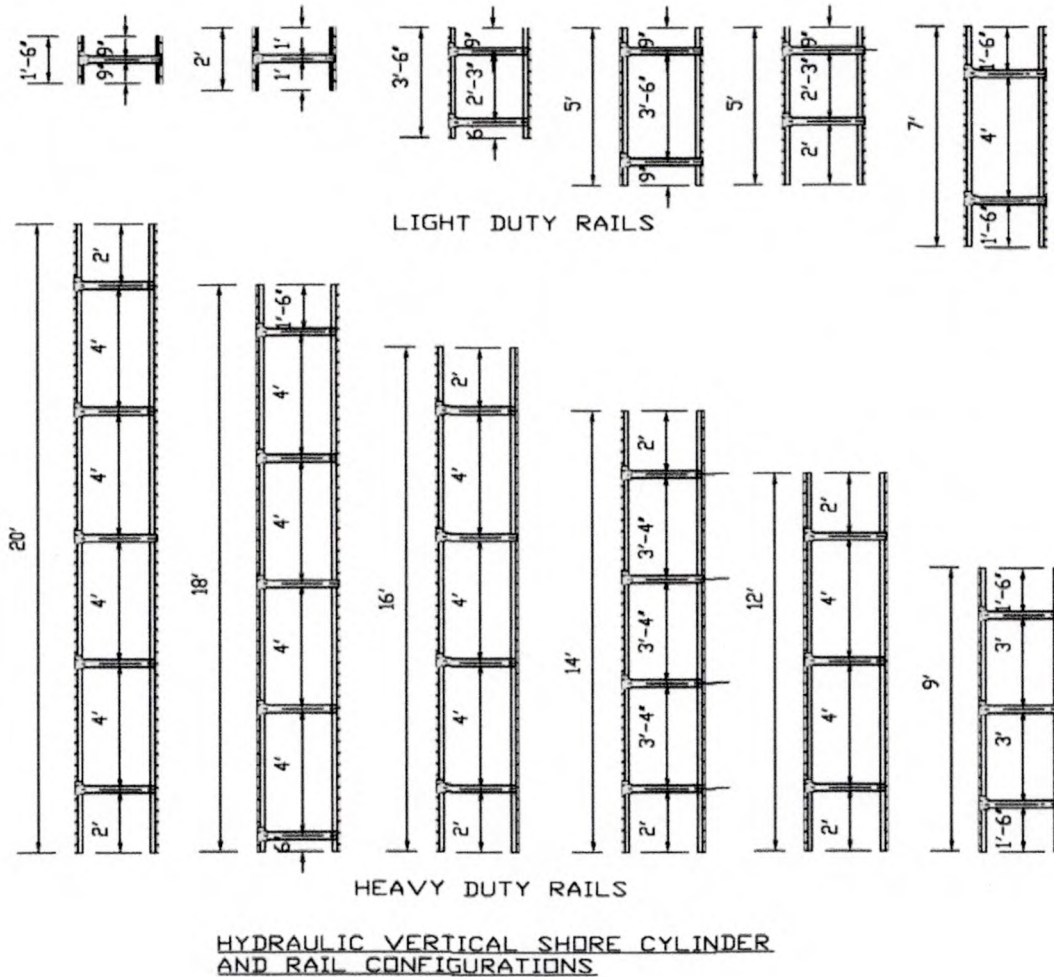

Figure 5 – Rail Dimensions

Note - Custom rail and cylinder spacing available upon request, however when using them with this tabulated data all spacing requirements of the data shall be met.

Hydraulic Cylinder Specifications

To configure for trench width, the proper cylinder range, extension if necessary, and oversleeve must be determined. **Table 3** lists some of the available cylinder ranges and some of the ranges with extensions.

Table 3- HYDRAULIC CYLINDER RANGE					
Extension (in)	Range		Extension (in)	Range	
	Cylinder (in)	w/ Extension (in)		Cylinder (in)	w/ Extension (in)
11	17-27	28-38	21	40-64	61-85
22		39-49	42		82-106
33		50-60	56		96-120
11	22-36	33-47	24	52-88	76-112
22		44-58	42		94-130
33		55-69	56		108-144
15	28-46	43-61	74	52-88	126-162
30		58-76	82		132-168
45		73-91	92		144-180
18	34-55	52-73	128		180-216
36		70-91			
54		88-109			

Oversleeve requirements are given in **Table 4** and shown in **Figures 6, 7, 8**.

Table 4-OVERSLEEVE REQUIREMENTS	
Trench Width	Oversleeve Required
to 8 ft	No oversleeve required
8 ft to 12 ft	3" x3/16" round aluminum oversleeve
12 ft to 15 ft	3-1/2" x 3-1/2" x 3/16" steel oversleeve

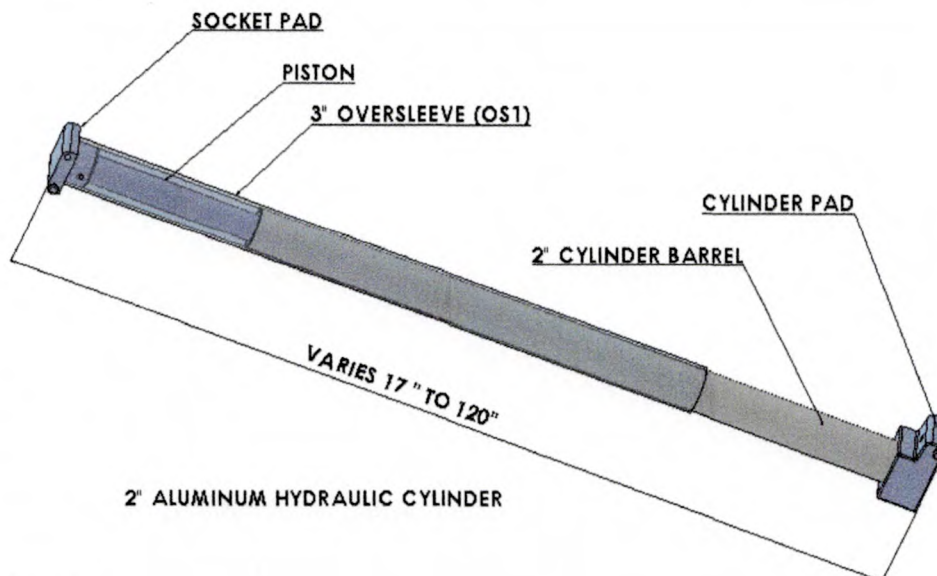

Figure 6

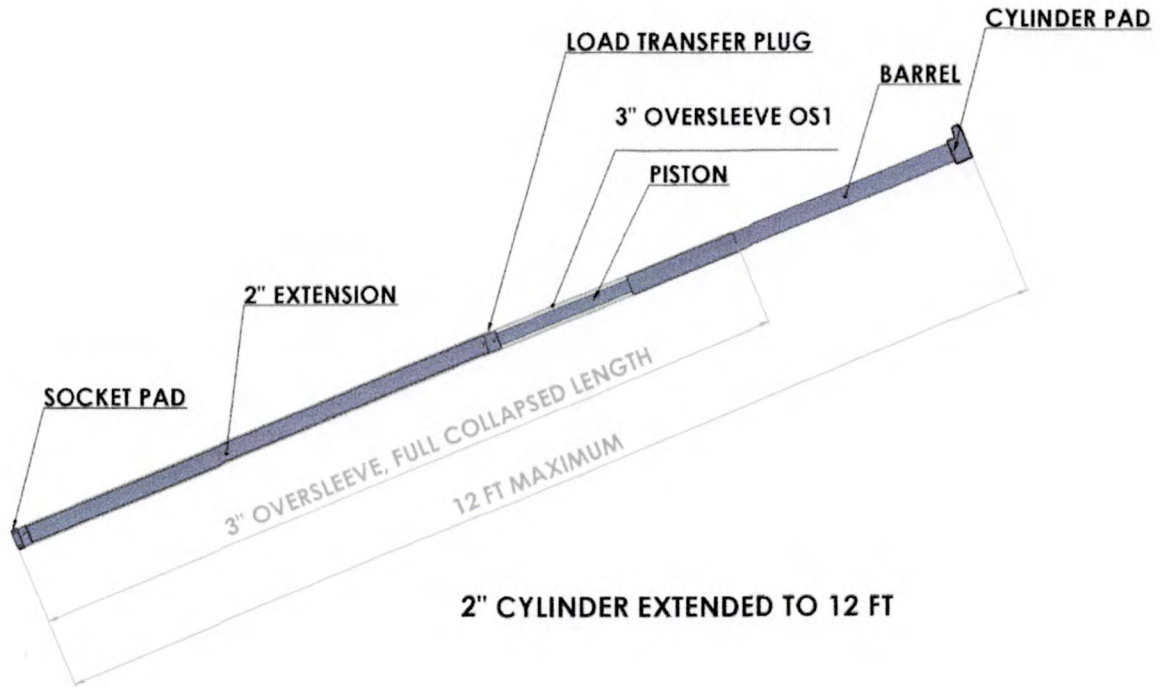

Figure 7

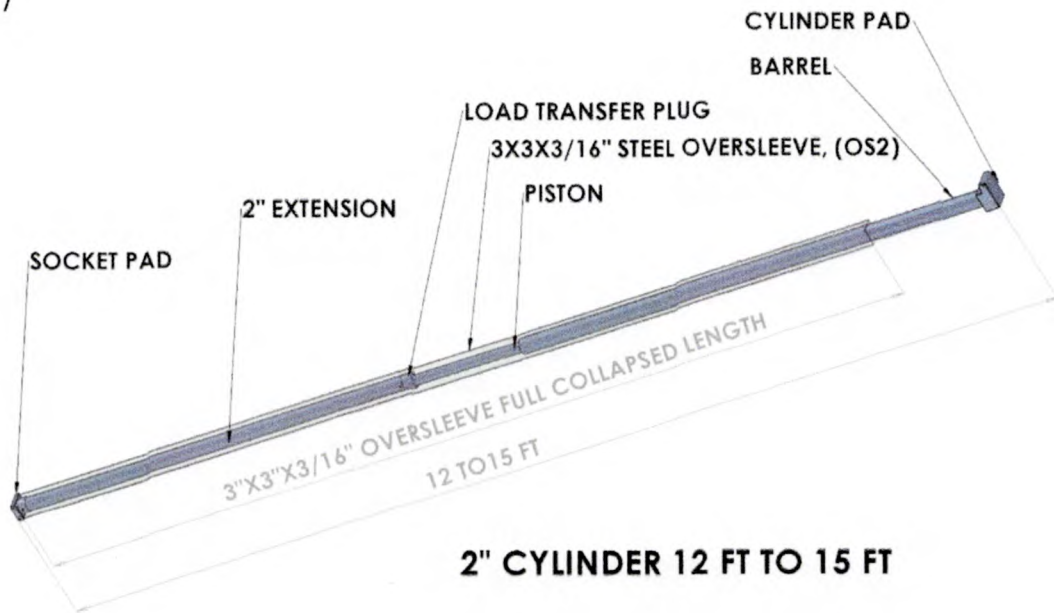

Figure 8



Vertical Aluminum Hydraulic Shore Installation and Removal Procedure

Required for installation

- Vertical Hydraulic Jack
- Pump with fluid and operating pressure gauge
- Release tool

Installation Procedure

- Step 1 Attach hydraulic hose to hydraulic fitting on shore. Open the valve on the pump can so that the shore cannot be pressurized. Set plywood if required and not attached to the shore into trench.
- Step 2 Lower shore into trench with folded up blade toward opposite trench wall and hydraulic fitting toward adjacent wall. After the shore is set to elevation, hold adjacent blade in place with release tool and let go of opposite blade allowing it to completely unfold and lock into position. In order for the shore to lock into position, the cylinder must be 90 degrees from the blade. Heavy or wide shores that cannot be safely lifted by one person should be set in with lifting equipment such as backhoe, boom truck or crane.
- Step 3 Close the valve on the pump can and pressurize the hydraulic shore to between 750 and 1500 psi. Pressure gauge should hold at pressure and not indicate any loss of pressure.
- Step 4 Remove the hydraulic hose by prying off with release tool. Clip hose to top of pump to prevent contamination by dragging it in the dirt. Move to next shore location and repeat process.

While trench shores are in place

- Check at least at start of shift for loose shores. This can be done by tapping the top of the shore with a metal rod; it will sound loose, sort of like kicking a tire to see if it is flat. Remove and replace loose shores.
- Check for sloughing or raveling. If it is occurring, sheeting must be used.
- Confirm that soil classification has not changed.

Required for Removal

- Vertical Hydraulic shore
- Release tool
- Removal tool or lifting equipment



**VERTICAL ALUMINUM
HYDRAULIC SHORING
TABULATED DATA**

Removal Procedure

Step 1 Place release tool over hydraulic fitting and removal hook in handle on opposite blade.

Step 2 Push release tool away to release fluid and pressure. Pull up on the removal hook to fold the shore up and then lift it out of trench.

Note - Depending on the length of the shore and width of the trench different installation procedures may be used. It is the responsibility of the contractor and his competent person to establish a safe installation and removal procedure for each application. All trench shore installers shall be instructed in the procedure prior to installing the shores.

Installation steps for use of Vertical Aluminum Hydraulic Trench Shores

Step 1 - Determine trench shoring requirements (Figure 9)

- Trench Depth
- Trench Width
- Trench Length

Note - Dewatering must be to the bottom of the excavation

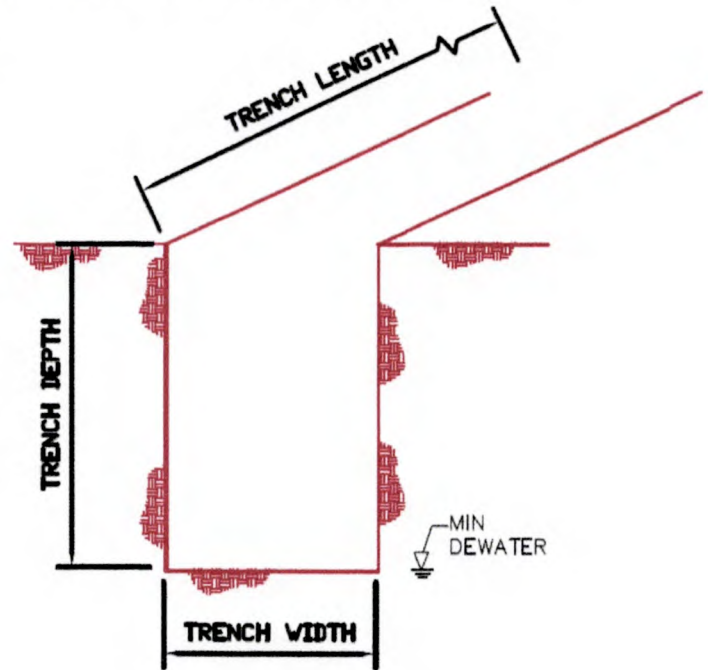

Figure 9 - Trench Parameters

Step 2 - Determine soil type in conformance with OSHA Appendix A

- Type A-25 Sloping $\frac{3}{4}$:1
- Type B-45 Sloping 1:1
- Type C-60 Sloping 1-1 $\frac{1}{2}$:1

Hydraulic Shores cannot be used in Type C-80 soil

Step 3 - Determine horizontal shore spacing (Figure 10)

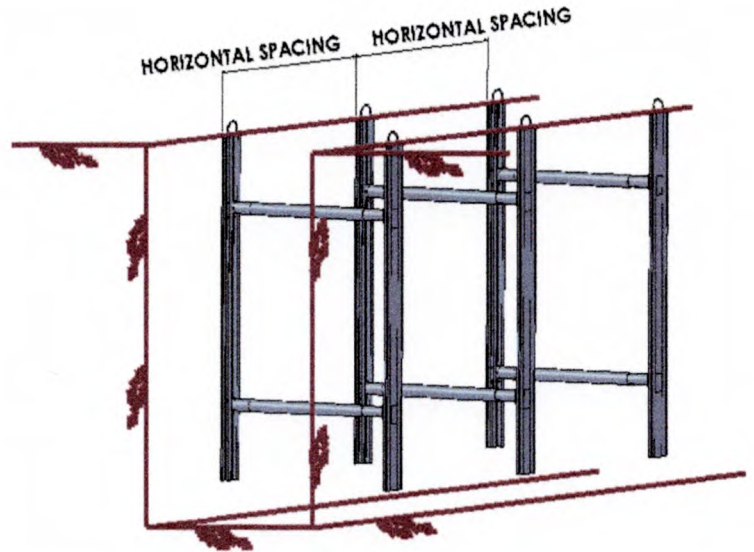

Figure 10 - Horizontal

Table 5 Notes

1. A competent person must decide whether trenches under 5 ft deep are stable or will require shoring.
2. Aluminum hydraulic shores are not allowed at any spacing in C-80 soil

Table 5-HORIZONTAL SHORE SPACING			
Depth ft	OSHA Soil Type		
	A	B	C-60
over 5 to 10	8	8	6
over 10 to 15	8	6	4
over 15 to 20	8	6	4
over 20 to 25	6	4	3

Step 4 - Determine vertical cylinder spacing (Figure 11)

Table 6-VERTICAL CYLINDER SPACING		
Between	Maximum	Minimum
	(ft)	(ft)
Top cylinder and surface	2	1
Between cylinders (note 3)	4	—
Bottom to first cylinder	4	—
Bottom of trench and lowest element of shoring (note 1)	—	2

Table 6 Notes

1. See OSHA 1926.652 (e) (2) Additional requirements for trench excavations (i)
2. — Indicates no limitation
3. When stacking hydraulic shores do not set hydraulic cylinders more than 4 ft apart

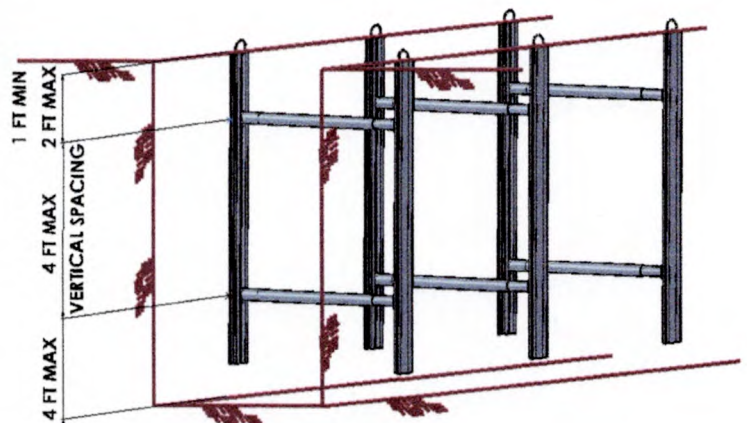

Figure 11 - Vertical

Step 5 - Determine Cylinder size and Oversleeve Requirement for trench width

Table 7-ALLOWABLE TRENCH WIDTH			
Depth	OSHA Type A, B, and C-60		
	Trench Width		
	To 8	8 to 12	12 to 15
(ft)	(ft)	(ft)	(ft)
to 5	2"	2" +OS 1	2" +OS2
over 5 to 10	2"	2" +OS 1	2" +OS2
over 10 to 15	2"	2" +OS 1	2" +OS2
over 15 to 20	2"	2" +OS2	2" +OS2
over 20 to 25	2"	2" +OS2	2" +OS2
Depth	OSHA Type B-45 Soil		
	Trench Width		
	To 8	8 to 12	12 to 15
(ft)	(ft)	(ft)	(ft)
to 5	2"	2" +OS 1	2" +OS2
over 5 to 10	2"	2" +OS 1	2" +OS2
over 10 to 15	2"	2" +OS2	2" +OS2
over 15 to 20	2"	2" +OS2	2" +OS2
over 20 to 25	2"	2" +OS2	2" +OS2
Depth	OSHA Type C-60 Soil		
	Trench Width		
	To 8	8 to 12	12 to 15
(ft)	(ft)	(ft)	(ft)
to 5	2"	2" +OS 1	2" +OS2
over 5 to 10	2"	2" +OS 1	2" +OS2
over 10 to 15	2"	2" +OS2	2" +OS2
over 15 to 20	2"	2" +OS2	2" +OS2
over 20 to 25	2"	2" +OS2	2" +OS2

OS 1 = 3" round x 3/16" wall aluminum oversleeve
OS2 = 3x3x3/16" wall square steel oversleeve

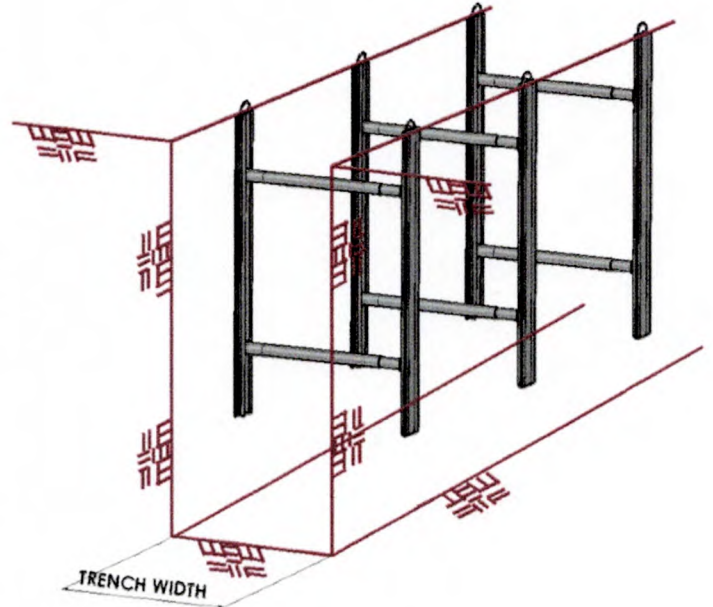

Figure 12 - Trench Width

**Step 6 - Determine sheeting requirements
(Figure 13)**

Table 8-SHEETING REQUIREMENTS			
Depth ft	OSHA Soil Type		
	A	B	C-60
to 8	Not Required	Not Required	Not Required
over 8 to 10	↓	↓	Required
over 10 to 15			
over 15 to 20			
over 20 to 25			

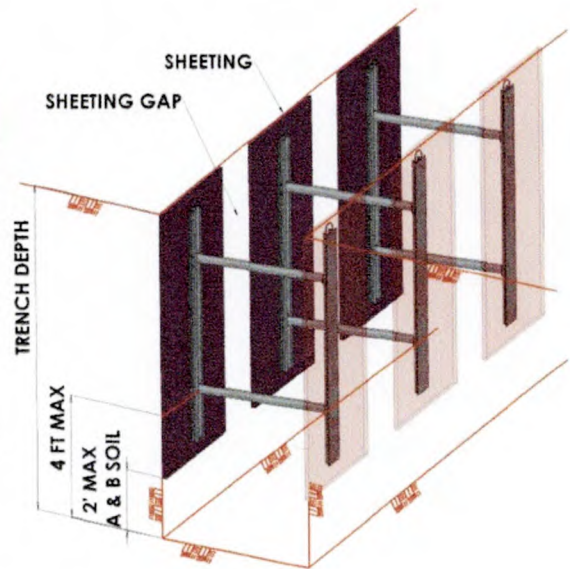

Table 8 Notes:

Figure 13 Sheeting Requirements

1. Sheeting is always required when sloughing or raveling occurs and in C-60 soil over 8' deep.
2. If there is a sheeting gap due to allowable shore spacing, the gap must be reduced until sloughing or raveling is prevented.
3. Sloughing is associated with soft cohesive soil that squeezes around the rail or sheeting. Raveling is associated with non-cohesive soil, sands and gravels that fall off the face of the trench wall. Trench wall face exposure over time can create raveling as moisture cohesion weakens due to drying.
4. Sheeting is not considered a structural part of the shore. Sheeting material requirements are strictly to meet minimum durability and handling requirements.
5. Sheeting may be set separately or connected to the shore.
6. In C-60 soil sheeting shall extend to the bottom of the excavation.
7. See Table 2 for allowable sheeting material.

Table 2-ALLOWABLE SHEETING			
Plywood		Other Materials	
3/4" Finn Form		1/2" thick steel plate 4 ft wide x depth	
3/4" Omni Form		Steel sheet piling	
3/4" plyform, Class 1 Exterior		Aluminum sheet piling	
3/4" HDO, High Density Overlay		Buildable box panels	
3/4" HDO, High Density Overlay			
3/4" 14 Ply Artic White Birch			
1-1/8" CDX			
2 sheets of 3/4" CDX			
Timber Lagging Set Horizontal			
Thickness	Soil Type/Span		
	A	B	C-60
2"	4 ft		
3"	5 ft	4 ft	
4"	8 ft	6 ft	4 ft
DF#2 or Oak			

Step 7 - Stacked Configurations (Figure 14)

- Shores may be stacked vertically as long as the hydraulic cylinders are no more than 4 ft apart
- Shores may be staggered as long as allowable shore spacing is not exceeded

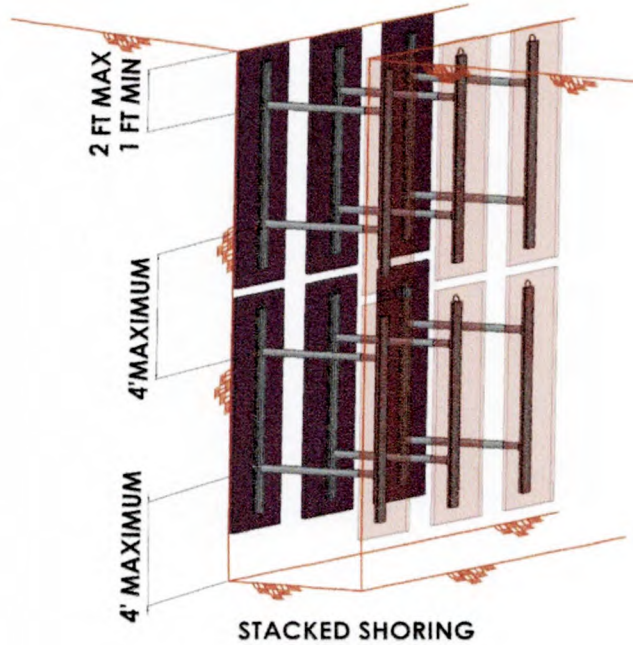
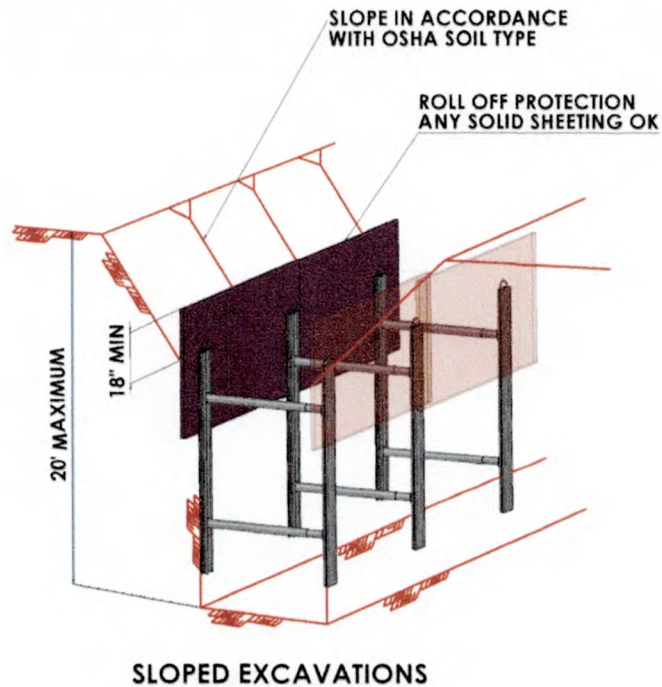
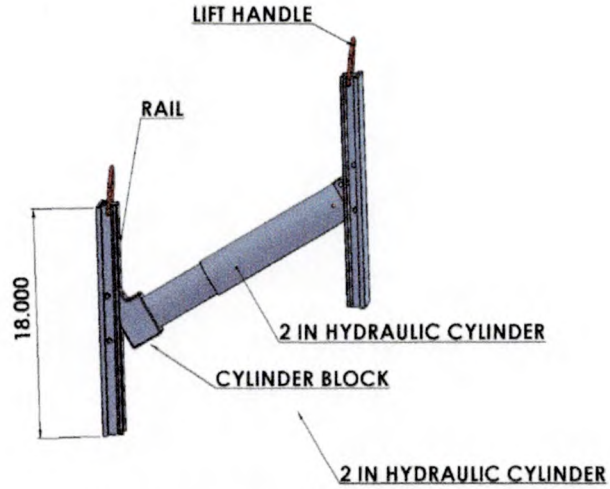

Figure 14

Step 8 - Combined sloping and shoring configurations



Step 9 - Single Hydraulic Shore



SINGLE HYDRAULIC SHORE

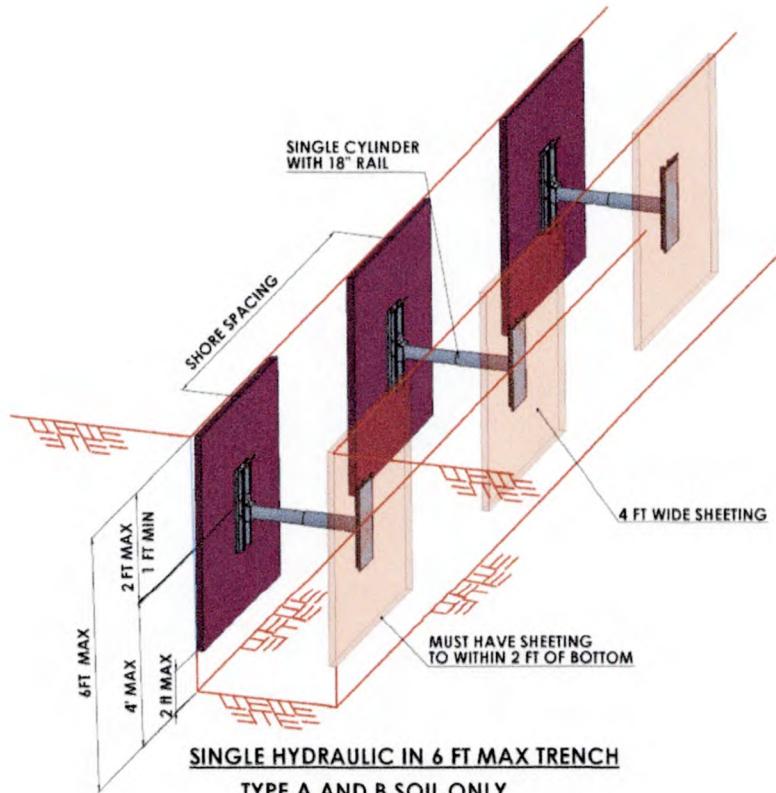

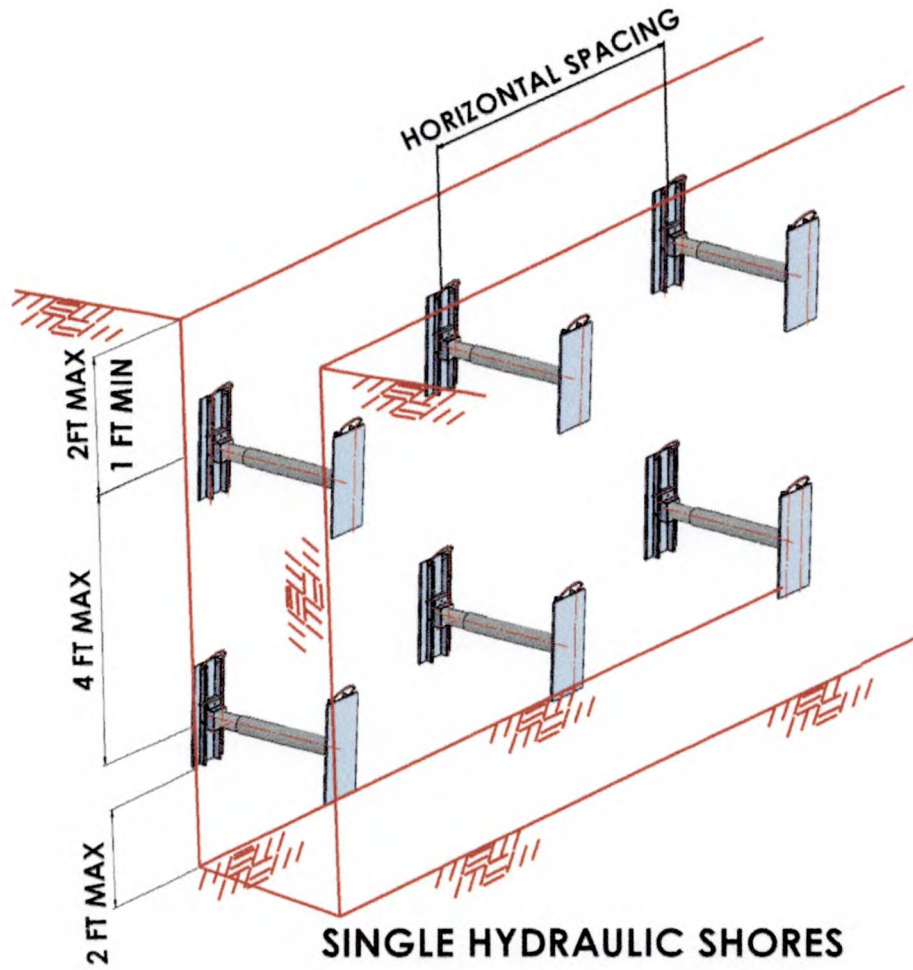

SINGLE HYDRAULIC SHORES

Safe Handling and Use of Trench Shores

By removing the shoring installer from the unshored trench and making shoring equipment more available and easy to install, trench jacks have no doubt had a huge impact on excavation safety. Utilizing trench jacks for shoring still has safety hazards that users should understand and protect workers from these hazards. These things happen rarely however it is still important that workers be informed of the risks they are taking before placing them at risk. The following are hazards and safety procedures associated with the use of trench jacks

- Injury to back and muscles from lifting heavy objects - An 8 ft long 52x88 extension trench jack weighs approximately 120 lbs. A two-man crew can safely lift, set and remove it from the trench. Anything longer or heavier should be lifted and set with equipment such as a backhoe or boom truck.
- Overhead lifting hazard - When jacks are being hoisted by sling from a tractor bucket or boom truck, the swinging jack presents a hazard to workers guiding it. Loose plywood and rocks can also fall off onto workers. Workers should stand clear and guide with a lead rope.
- Finger and hand protection - Trench jacks have moving parts at the connection between the cylinder and the rail. When the jack swings open fingers can be crushed under the cylinder block and when it is swung closed fingers can easily be sheared off if they are between the block and the rail leg. When the hydraulic hose is being connected to the block, fitting and when the jack is being lifted by hand shearing and crushing is most likely to happen.

Awareness through safety instruction and hand placement a safe distance, 12", from the blocks is safe practice. Trench jacks may have optional finger guards however, it is still possible to get fingers under the block and wrists cut and banged when the jack folds or unfolds.

See **Figure 15**.

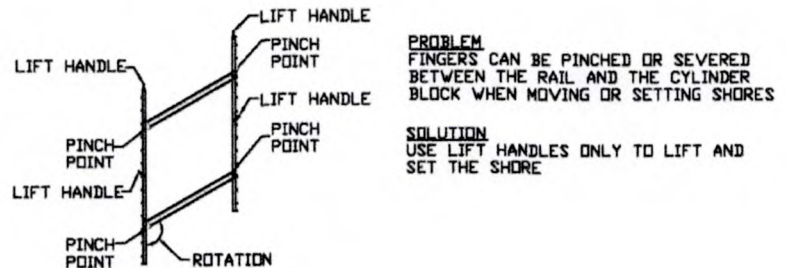

Figure 15. Trench Safety issues

- Bank collapse with worker standing on it - When the jack is being set it is still possible for the trench wall to collapse from the additional weight and activity going on around it. Trench jack installation should closely follow the excavation activity.

During jack removal, the arch column is being literally removed with the load still on it. Pipe bedding and initial backfill cut the trench depth adding some stability prior to removing the jack. If backfill operations are closely following jack removal, the length of unshored collapsible trench wall becomes short. Soil arching back to the backfilled area is likely and trench wall failure becomes less likely. Remote backfill operation such as

excavator wheel or vibraplate, or remote operated compactors must always be used for compaction outside the shored area. When trench jacks are being removed to allow pipe installation and then reset there is a greater likelihood of trench wall collapse. Equipment and personnel in close proximity are at risk of loosing the ground under their feet. Keep equipment and personnel except those needed to remove the jack a safe distance away. This type of operation is not uncommon and most often works safely, however if there is any evidence of trench wall collapse the operation should be discontinued and a different method of getting production materials into the trench or a different shoring system should be used. Several bad accidents have occurred in conjunction with this type of operation.

- Get the surcharge loads right - Equipment over 20,000 lbs and large spoil piles over 2 ft high quickly add additional surcharges, especially in the top 10 ft, that can easily overload the trench jack. If one cylinder fails, a progressive failure to the bottom of the trench and then down the length of the trench is possible. A boom truck or backhoe outrigger placed next to a trench jack can trigger this. The way to adjust for additional surcharge load is to move the load away from the trench, spread the load with timber pad or steel plate, or decrease the trench jack spacing. Centering the load on the jack, places most of the load on that jack. The alternative, centering the load between the jacks distributes the load evenly between the jacks, however it increases the possibility of the arch void to fall out or arch shear failure at the jack. One alternative may not be any better than the other.

- Trench Jack fold-up failure - If all of the jacks were unfolded into the trench from one side of the trench, it is possible to get a bank failure that can lift the rotating jack leg. This type of failure is not common; however, the author has spoken with more than one worker that has, fortunately from outside the trench, witnessed this type of failure.

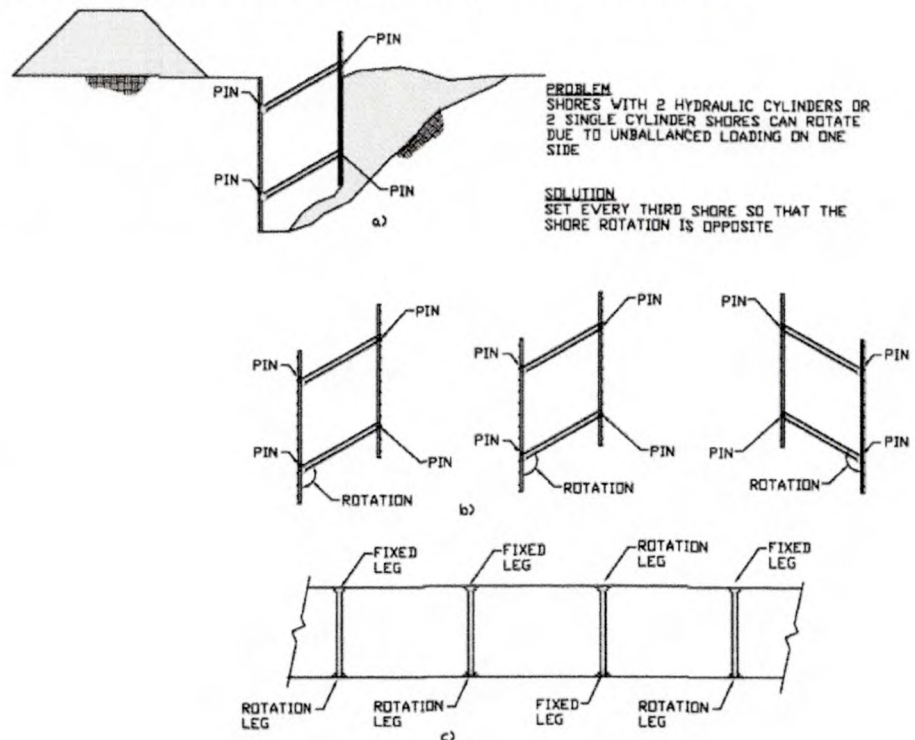

Figure 16. a) Trench jack fold up failure, b) leg rotation, c) jack rotation to prevent fold up failure

No workers were inside the trench. The story goes that 40 ft of trench folded up the jacks and collapsed. The solution is to rotate the jack so that the rotation leg is on the other side of the trench. The problem is that the installers have to move to the other side of the trench to set and pressurize the jack. Two soil conditions that this would be most likely to happen are in medium dense to loose non-cohesive soils and soft clays with high surcharge loads. See **Figure 16**

- Loose trench jacks in the trench - Jacks that are not pressurized in the trench are not setting up arching and preventing trench collapse. In this condition the jacks can also fall down on workers below them. Jacks should not leak at all. Pressure can change slightly up or down due to temperature changes or increase due to loading however it should never loosen up in the ditch. If jacks are left overnight they should be checked before entering the trench in the morning. Simply tap them with a hammer or bar of metal, they will sound loose if they are. Remove and replace jacks that bleed off. If the trench wall has voids where the cylinder hits the wall, use wood blocking to extend the connection to the soil.
- Non-vertical trench walls - Trench walls that are not vertical, an inverted A shape, the trench jack is not stable. Assuming a coefficient of friction of 0.1 between the soil and the aluminum rail and applying a factor of safety of 1.5 calculations indicate that the slope of the trench wall should not exceed 3 degrees or the jack will lift up and fail to provide an arching point.
- In trenches that are sloped above, extending the jack 18" above the hinge point does not provide roll off protection for workers below due to the fact that the jack is spaced. Place fabric or boards behind the jack rail to stop objects at the surface and bank ravel from falling on workers, See **Figure 17**.

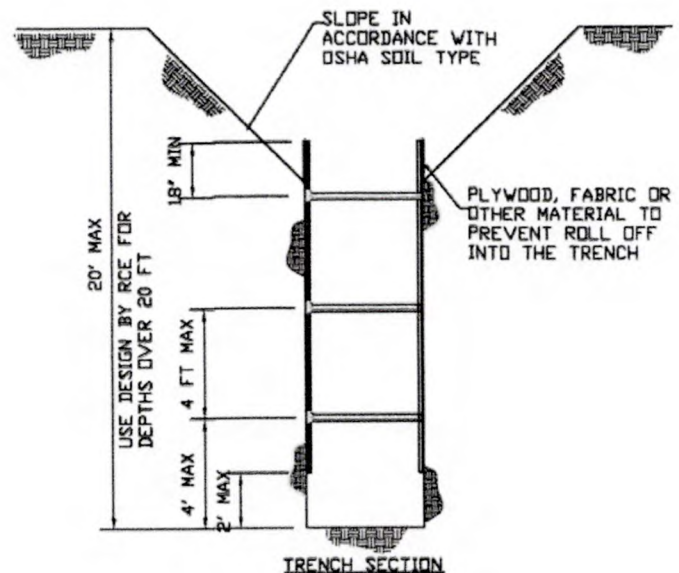

Figure 17. Trench Safety issues



Subpart P Additional Requirements Related to Hydraulic Shoring with Commentary

The following are excerpts from Subpart P that are relative to hydraulic shoring use.

1926.652(e)(1)(ii) Support systems shall be installed and removed in a manner that protects employees from cave-ins, structural collapses, or from being struck by members of the support system.

1926.652(e)(2)(ii)

Installation of a support system shall be closely coordinated with the excavation of trenches.

Commentary - Hydraulic shores were developed so that they could be installed and removed from outside the excavation. Cave-in from the surface is still a hazard while installing and removing the shore. Hydraulic shores should be installed as soon as possible after the trench is excavated. This means that if the shores are being installed horizontally at 6 ft on center there should be no more than 6 to 10 ft of trench unshored at any time. It is not acceptable to open a length of trench and then go back and install the shores later.

When hydraulic shores are being removed use caution, stand away from the trench edge and backfill as close to the shore removal location as possible.

It is not allowed to remove and replace a hydraulic shore in order to install production work that will not fit within the shore spacing. If a hydraulic shore is being removed and replaced in order to set pipe into the excavation the soil arching support that was originally set up is being removed similar to removing a column from under an arch. Collapse is imminent and can occur immediately or at the time of resetting the shore.

1926.652(f) Sloping and benching systems. Employees shall not be permitted to work on the faces of sloped or benched excavations at levels above other employees except when employees at the lower levels are adequately protected from the hazard of falling, rolling, or sliding material or equipment.

Commentary - When hydraulic shores are used in sloped excavations without sheeting some form of roll off protection must be provided.

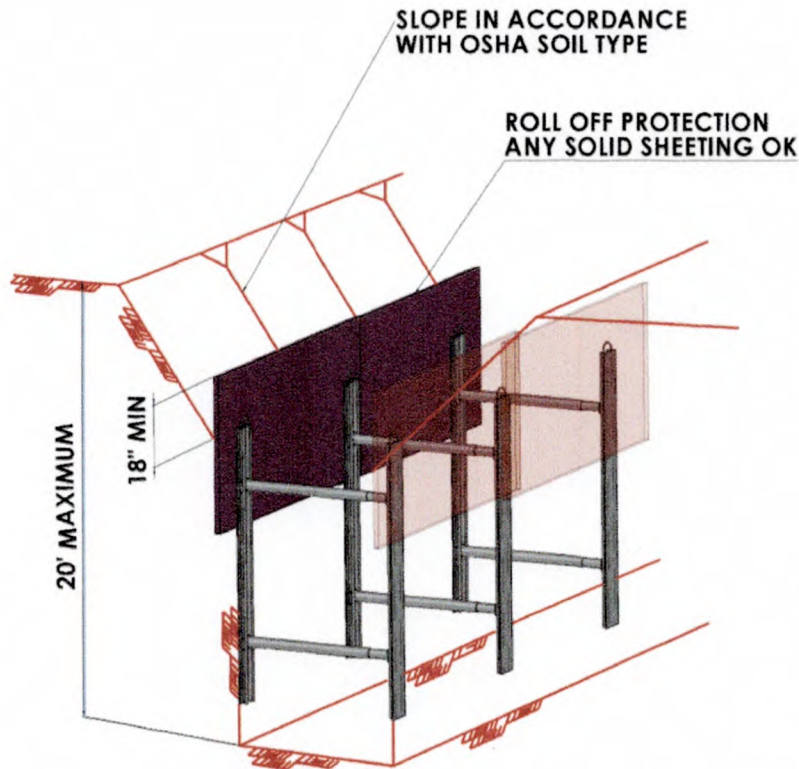

SLOPED EXCAVATIONS

1926.652(e)(2)(i) Excavation of material to a level no greater than 2 feet (.61 m) below the bottom of the members of a support system shall be permitted, but only if the system is designed to resist the forces calculated for the full depth of the trench, and there are no indications while the trench is open of a possible loss of soil from behind or below the bottom of the support system.

Commentary - Either the rail or the plywood must be within 2 ft of the bottom of the excavation.

1926.652(d)(2) Manufactured materials and equipment used for protective systems shall be used and maintained in a manner that is consistent with the recommendations of the manufacturer, and in a manner that will prevent employee exposure to hazards.

Commentary - Daily inspections are required to check for equipment malfunctions.



ROAD PLATE WITH or WITHOUT CARBIDE SKID RESISTANT SURFACE TABULATED DATA Effective 11-15-16

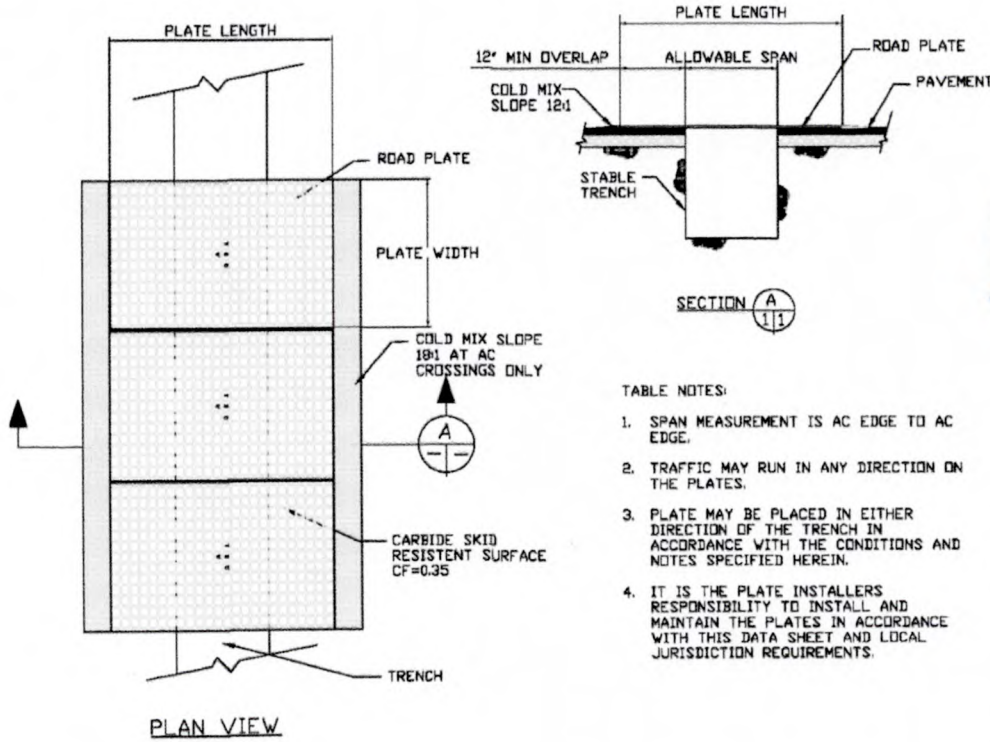

TABLE NOTES:

1. SPAN MEASUREMENT IS AC EDGE TO AC EDGE.
2. TRAFFIC MAY RUN IN ANY DIRECTION ON THE PLATES.
3. PLATE MAY BE PLACED IN EITHER DIRECTION OF THE TRENCH IN ACCORDANCE WITH THE CONDITIONS AND NOTES SPECIFIED HEREIN.
4. IT IS THE PLATE INSTALLERS RESPONSIBILITY TO INSTALL AND MAINTAIN THE PLATES IN ACCORDANCE WITH THIS DATA SHEET AND LOCAL JURISDICTION REQUIREMENTS.

Table 1-ALLOWABLE SPANS AND WEIGHTS FOR STEEL ROAD PLATES

Plate Thickness	Allowable Span	Plate Size / Weight					
		Size	Weight (lbs)	4'x5'	4'x6'	4'x8'	5'x10'
1"	2.5'	Size	816				
		Weight (lbs)	979	1306			
	4.5'	Size	1632	2040			
		Weight (lbs)	1958	2448	2938		
		Size	3264	3917	4896	5222	6528
		Weight (lbs)					
1.25"	7'	Size	4080				
Weight (lbs)							
1.5"	10'	Size	5875	7344	7834	9792	
		Weight (lbs)					

Note-Plates must always be set in a direction that provides a 1' overlap on the each side of the excavation

Table 2-ALLOWABLE SPANS AND WEIGHTS FOR DOUBLE STACKED STEEL ROAD PLATES

Plate Thickness	Allowable Span	Plate Size / Weight					
		Size	Weight (lbs)	5'x10'	6'x10'	6'x12'	8'x15'
2-1"	8'	Size	4080				
		Weight (lbs)	4896	5875			
		Size	6528	7834	9792	10445	13056
		Weight (lbs)					
2-1.25"	11'	Size	14688	15667	19584		
Weight (lbs)							
2-1.5"	15'	Size	19584				
		Weight (lbs)					

Note-Plates must always be set in a direction that provides a 1' overlap on each side of the excavation

General Conditions



ROAD PLATE WITH or WITHOUT CARBIDE SKID RESISTANT SURFACE TABULATED DATA Effective 11-15-16

1. Plates are minimum ASTM A36 Min Fy= 36 ksi
2. Trench plate installations including cold mix ramping within the City of Los Angeles and all pavement repairs shall be in accordance Los Angeles Public Works Standard S-601-3, WATCH Manual and all other jurisdiction requirements.
3. Plates are designed for HS20-44 and HL-93 axel loading with 1.33 impact factor
4. Design is based on allowable bending strength
5. Minimum overlap is 12"
6. There shall be no paint on the surface of the road plates.
7. When skid resistance is required, the non-skid surface shall have a dynamic coefficient of friction of 0.35 per California Test Method No. 342 or equivalent skid number of 0.35 as tested per ASTM E274. Any trench plate with non-skid surface less than specified frictional resistance shall be removed and replaced
8. This data sheet applies to general use in all locations, areas where skid resistance is required and where it is not required.
9. All road plates with carbide skid resistant surface are manufactured in Trench Shoring Company Plant at 206 N. Central Ave., Compton, CA 90220.
10. All tops of the road plates must be flush.

CER, Inc.
Construction Engineering Resource, Inc.
1837 Wright Street
Santa Rosa, CA 95404
(707) 484-4704 jmtengr2@aol.com



TEST HOLE DATA REPORT

TEST HOLE NO: PH-01A
 TEST HOLE DATE: 10/25/2022
 PROJECT NO: CA12700205



CLIENT TEST HOLE NO: PH-01A
 SUE CREW/TRUCK NO: SA/RG/550422
 CITY,COUNTY: MALIBU / LOS ANGELES

LA COUNTY DEPT. OF
 CLIENT: PUBLIC WORKS
 PROJECT: COASTLINE 12 WATER
 LINE REPLACEMNT

5622 Research Drive Suite A
 Huntington Beach, California 92649
 TEL:714.487.5780
 www.T2ue.com

LOCATION/INTERSECTION:
CASTLEROCK AND COASTLINE

MAP



SITE PHOTO - FACING NORTH



CROSS SECTION - NOT TO SCALE

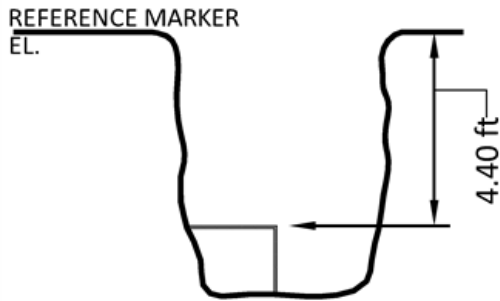

TEST HOLE - UTILITY - FACING NORTH



DISCLAIMER: ADDITIONAL MATERIAL AND/OR UTILITIES MAY EXIST BELOW APPARENT BOTTOM

UTILITY DESCRIPTION		REFERENCE MARKER	
UTILITY TYPE	ELECTRIC	LOCATION	EAST EDGE
UTILITY MATERIAL	CONCRETE	MARKED BY	NAIL & DISK
UTILITY DIRECTION	NORTH - SOUTH	STATION	
UTILITY WIDTH (FIELD)	-	OFFSET	-
UTILITY WIDTH (RECORD)		OFFSET FROM	
APPARENT UTILITY OWNER	EDISON, FRONTIER	SWING TIES FROM STRUCTURE	APPROX DISTANCE
DEPTH FROM REFERENCE MARKER		A	90 DEG N/O FH 22.80'
TOP OF UTILITY	4.40'	B	90 DEG E/O FH 4.50'
BOTTOM OF UTILITY	5.70'	C	-
ELEVATION OF UTILITY			
TOP OF UTILITY	-		
APPARENT BOTTOM OF UTILITY	-		
SURFACE			
TYPE	ASPHALT		
THICKNESS	6.00"		

REMARKS:
 CONFIRMED MARKS AND REOPENED PH01, REMOVED A LARGE AMOUNT OF ROCKS AND WERE ABLE TO UNCOVER EAST EDGE OF AN ENCASEMENT. WE TRIED CLEARING AS MUCH AS WE COULD ON TOP AND BOTTOM OF ENCASEMENT AND COULD FIND NO OTHER STRUCTURE AND COULD NOT TEL OF THIS IS ELECTRIC OF TELCOM. CALLED BRAD AND WERE TOLD TO CLOSE

REVISION NOTES:

REVIEWED DATE: 10/27/2022 CHECKED DATE: 10/27/2022 REVISION DATE:
 REVIEWED BY: rh CHECKED BY: rh

TEST HOLE DATA REPORT

TEST HOLE NO: PH03
 TEST HOLE DATE: 9/14/2022
 PROJECT NO: CA12700205



CLIENT TEST HOLE NO: PH03
 SUE CREW/TRUCK NO: CG/JDW/603
 CITY,COUNTY: MALIBU / LOS ANGELES

LA COUNTY DEPT. OF
 CLIENT: PUBLIC WORKS
 PROJECT: COASTLINE 12 WATER
 LINE REPLACEMNT

5622 Research Drive Suite A
 Huntington Beach, California 92649
 TEL:714.487.5780
 www.T2ue.com

LOCATION/INTERSECTION:
 18132 COASTLINE DR.

MAP



SITE PHOTO - FACING NE



CROSS SECTION - NOT TO SCALE

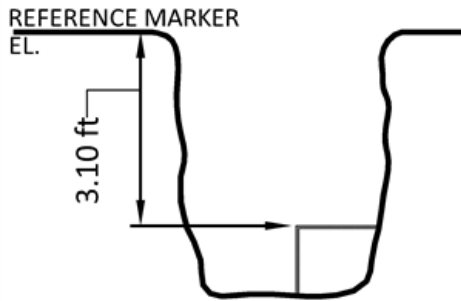

TEST HOLE - UTILITY - FACING NE



DISCLAIMER: ADDITIONAL MATERIAL AND/OR UTILITIES MAY EXIST BELOW APPARENT BOTTOM

UTILITY DESCRIPTION

UTILITY TYPE: ELECTRIC
 UTILITY MATERIAL: CONCRETE
 UTILITY DIRECTION: NORTH - SOUTH
 UTILITY WIDTH (FIELD): -
 UTILITY WIDTH (RECORD): -
 APPARENT UTILITY OWNER: SOCAL EDISON

REFERENCE MARKER

LOCATION: WEST EDGE
 MARKED BY: NAIL & DISK
 STATION: -
 OFFSET: -
 OFFSET FROM: -

DEPTH FROM REFERENCE MARKER

TOP OF UTILITY: 3.10'
 BOTTOM OF UTILITY: 4.20'

SWING TIES FROM STRUCTURE APPROX DISTANCE

A: 90 DEG S. of MH2: 20.90'
 B: 90 DEG W. of MH2: 5.50'
 C: -

ELEVATION OF UTILITY

TOP OF UTILITY: -
 APPARENT BOTTOM OF UTILITY: -

SURFACE

TYPE: ASPHALT
 THICKNESS: 8.00"

REMARKS:
 OPENED HOLE ON WEST EDGE OF TELCOM ENCASMENT

REVISION NOTES:

REVIEWED DATE: 9/23/2022

CHECKED DATE:

REVISION DATE:

REVIEWED BY: rh

CHECKED BY:

TEST HOLE DATA REPORT



TEST HOLE NO: PH05
 TEST HOLE DATE: 9/14/2022
 PROJECT NO: CA12700205

CLIENT TEST HOLE NO: PH05
 SUE CREW/TRUCK NO: CG/JDW/603
 CITY,COUNTY: MALIBU / LOS ANGELES

CLIENT: LA COUNTY DEPT. OF PUBLIC WORKS
 PROJECT: COASTLINE 12 WATER LINE REPLACEMENT

5622 Research Drive Suite A
 Huntington Beach, California 92649
 TEL: 714.487.5780
 www.T2ue.com

LOCATION/INTERSECTION:
 18074 COASTLINE DR.

MAP



SITE PHOTO - FACING NORTH



CROSS SECTION - NOT TO SCALE

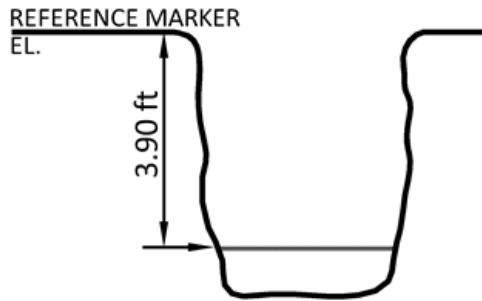

TEST HOLE - UTILITY - FACING NE



DISCLAIMER: ADDITIONAL MATERIAL AND/OR UTILITIES MAY EXIST BELOW APPARENT BOTTOM

UTILITY DESCRIPTION

UTILITY TYPE: ELECTRIC
 UTILITY MATERIAL: CONCRETE
 UTILITY DIRECTION: NORTH - SOUTH
 UTILITY WIDTH (FIELD): -
 UTILITY WIDTH (RECORD): -
 APPARENT UTILITY OWNER: SCE

REFERENCE MARKER

LOCATION: WEST EDGE
 MARKED BY: NAIL & DISK
 STATION: -
 OFFSET: -
 OFFSET FROM: -

DEPTH FROM REFERENCE MARKER

TOP OF UTILITY: 3.90'
 BOTTOM OF UTILITY: -

SWING TIES FROM STRUCTURE APPROX DISTANCE

A: 90 DEG N. of FH2: 29.20'
 B: 90 DEG W. of FH2: 10.20'
 C: -

ELEVATION OF UTILITY

TOP OF UTILITY: -
 APPARENT BOTTOM OF UTILITY: -

SURFACE

TYPE: ASPHALT
 THICKNESS: 10.00"

REMARKS:

OPENED HOLE TO THE WEST OF TELCOM ALIGNMENT TO OBTAIN EDGE AND FOUND TOP OF ENCASUREMENT. TRIED TO PROBE OUT TO THE WEST AND COULD ONLY FEEL EDGE. WILL NEED TO ANOTHER HOLE TO OBTAIN BOTTOM., SEE PH-5A

REVISION NOTES:

REVIEWED DATE: 9/23/2022
 REVIEWED BY: rh

CHECKED DATE:
 CHECKED BY:

REVISION DATE:

TEST HOLE DATA REPORT



TEST HOLE NO: PH05A
 TEST HOLE DATE: 9/14/2022
 PROJECT NO: CA12700205

CLIENT TEST HOLE NO: PH05A
 SUE CREW/TRUCK NO: CG/JDW/603
 CITY, COUNTY: MALIBU / LOS ANGELES

LA COUNTY DEPT. OF
 CLIENT: PUBLIC WORKS
 PROJECT: COASTLINE 12 WATER
 LINE REPLACEMENT

5622 Research Drive Suite A
 Huntington Beach, California 92649
 TEL: 714.487.5780
 www.T2ue.com

LOCATION/INTERSECTION:
 18074 COASTLINE DR.

MAP



SITE PHOTO - FACING NORTH



CROSS SECTION - NOT TO SCALE

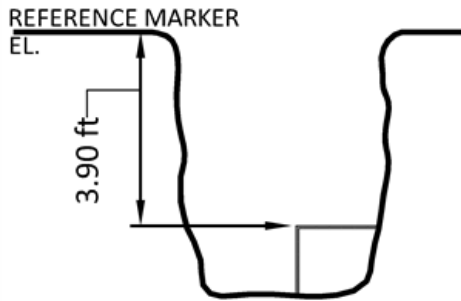

TEST HOLE - UTILITY - FACING NORTH

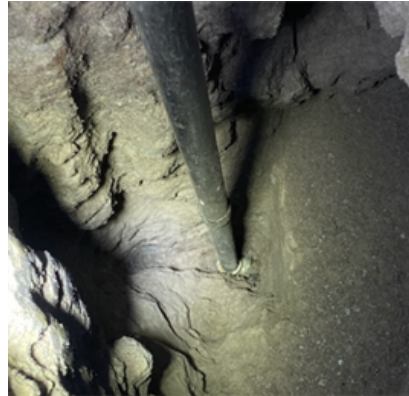

DISCLAIMER: ADDITIONAL MATERIAL AND/OR UTILITIES MAY EXIST BELOW APPARENT BOTTOM

UTILITY DESCRIPTION:

UTILITY TYPE: TELECOM
 UTILITY MATERIAL: CONCRETE
 UTILITY DIRECTION: NORTH - SOUTH
 UTILITY WIDTH (FIELD): -
 UTILITY WIDTH (RECORD): -
 APPARENT UTILITY OWNER: SCE

REFERENCE MARKER

LOCATION: WEST EDGE
 MARKED BY: NAIL & DISK
 STATION: -
 OFFSET: -
 OFFSET FROM: -

DEPTH FROM REFERENCE MARKER

TOP OF UTILITY: 3.90'
 BOTTOM OF UTILITY: 5.20'

SWING TIES FROM STRUCTURE APPROX DISTANCE

A 90 DEG N. OF FH2 29.20'
 B 90 DEG W. OF FH2 10.20'
 C -

ELEVATION OF UTILITY

TOP OF UTILITY: -
 APPARENT BOTTOM OF UTILITY: -

SURFACE

TYPE: ASPHALT
 THICKNESS: 10.00"

REMARKS:
 OPENED 2ND HOLE TO GET TOP, BOTTOM AND WEST EDGE OF TELCOM ENCASUREMENT

REVISION NOTES:

REVIEWED DATE: 9/23/2022
 REVIEWED BY: rh

CHECKED DATE:
 CHECKED BY:

REVISION DATE:

TEST HOLE DATA REPORT

TEST HOLE NO: PH06
 TEST HOLE DATE: 9/15/2022
 PROJECT NO: CA12700205



CLIENT TEST HOLE NO: PH06
 SUE CREW/TRUCK NO: JW/JWII/550603
 CITY,COUNTY: MALIBU / LOS ANGELES

LA COUNTY DEPT. OF
 CLIENT: PUBLIC WORKS
 PROJECT: COASTLINE 12 WATER
 LINE REPLACEMNT

5622 Research Drive Suite A
 Huntington Beach, California 92649
 TEL: 714.487.5780
 www.T2ue.com

LOCATION/INTERSECTION:
 18056 COASTLINE DR.

MAP



SITE PHOTO - FACING NORTH



CROSS SECTION - NOT TO SCALE

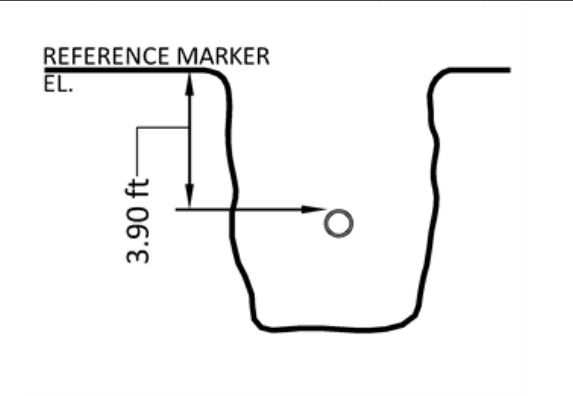

TEST HOLE - UTILITY - FACING NORTH



DISCLAIMER: ADDITIONAL MATERIAL AND/OR UTILITIES MAY EXIST BELOW APPARENT BOTTOM

UTILITY DESCRIPTION	REFERENCE MARKER		
UTILITY TYPE	GAS SERVICE	LOCATION	CENTER OF UTILITY
UTILITY MATERIAL	METALLIC (IRON, STEEL, COATED)	MARKED BY	NAIL & DISK
UTILITY DIRECTION	NORTH - SOUTH	STATION	
UTILITY WIDTH (FIELD)	1.00"	OFFSET	-
UTILITY WIDTH (RECORD)		OFFSET FROM	
APPARENT UTILITY OWNER	SOCAL GAS	SWING TIES FROM STRUCTURE	APPROX DISTANCE
DEPTH FROM REFERENCE MARKER		A	90 DEG. N. OF MH3 36.50'
TOP OF UTILITY	3.90'	B	90 DEG E. OF MH3 67.10'
BOTTOM OF UTILITY	-	C	-
ELEVATION OF UTILITY			
TOP OF UTILITY	-		
APPARENT BOTTOM OF UTILITY	-		
SURFACE			
TYPE	ASPHALT		
THICKNESS	6.00"		

REMARKS:
 FOUND TARGET GASLINE

REVISION NOTES:

REVIEWED DATE: 9/23/2022 CHECKED DATE: _____ REVISION DATE: _____
 REVIEWED BY: rh CHECKED BY: _____